



PG

SERVICE MANUAL

SCREW COMPRESSOR

PDS185S-6C1
PDS185SR-6C1



FAC-52P (NISSAN)

Preface

This service manual explains about the cautions for maintenance jobs and is to serve a guide for the electric system, and troubleshooting for service personnel.

In this book the fundamental matters and other things already mentioned in the “Instruction Manual” and the “Parts Catalogue” are omitted to avoid duplication.

Therefore, for the operation and handling of this unit, we request you to refer to the instruction manual and caution plates, and further for the structure and components of the unit, please refer to the “Parts Catalogue” separately to be supplied with the unit.

If you should find any description which does not coincide with the instruction manual and parts catalog, we request you to make sure to start the job after clarifying it.

Service personnel is required to safely take quick and proper countermeasures as well as to use correct technology of maintenance in case of field services and periodical maintenance.

It is important that service personnel should have proper and sufficient knowledge about the structure and function of the unit and should be well familiar with such technique mentioned in them.

Copies of this service manual are intended to be distributed to limited numbers of our customers. The unauthorized reproduction or distribution of this service manual is prohibited.

Table of Contents

1. Specification	1-1
1.1 Specifications	1-1
1.2 Set Value	1-3
1.3 Outline drawing	1-4
1.4 Internal Components and Part Names	1-7
1.5 Instrument panel	1-9
1.6 Capacity Control Device	1-12
1.7 Piping Diagram	1-15
1.8 Fuel piping	1-16
2. Maintenance	2-1
2.1 Cautions for Overhauling	2-1
2.2 Tightening torque	2-2
2.3 How to adjust regulator and how to replace diaphragm	2-3
2.4 Clean the strainer provided inside the engine feed pump	2-6
2.5 Clean the strainer provided inside the sedimenter	2-7
2.6 Change fuel filter (sedimenter built-in type)	2-7
2.7 Change Oil Separator	2-8
2.8 Change O-Ring of Unloader	2-8
2.9 Check O-ring and Needle valve of Auto-relief valve and Vacuum relief valve	2-9
2.10 Performance check of Pressure control valve	2-9
2.11 Check Pressure Control Valve O-Ring and Piston	2-9
2.12 Clean inside of Fuel Tank	2-10
2.13 Change of pellet assembly of by-pass valve	2-10
2.14 Values of Various Adjustments of Engine	2-11
3. Electric System	3-1
3.1 Engine electric appliances	3-1
4. Troubleshooting	4-1
4.1 Repairing Procedures	4-1
4.2 Failures of compressor and engine	4-3
4.3 Operation of emergency switch	4-11
4.4 Others	4-14
4.5 Explanation of trouble diagnosis	4-15
5. References	5-1
5.1 Comparison between consumable parts and electrical appliances	5-1
5.2 Engine Wiring Diagram	5-3

1. Specification

1.1 Specifications

Item	unit	PDS185S-6C1 (VE PUMP Type)		PDS185S-6C1R (IN LINE PUMP Type) for Asian countries
		for 55HP USA	for 49HP USA	
●Weight · Mass				
Overall length	in.(mm)	121 (3,070)	←	117 (2,960)
Overall length (Bonnet only)	in.(mm)	73 (1,860)	←	←
Overall width	in.(mm)	66 (1,665)	←	65 (1,650)
Overall height	in.(mm)	57 (1,450)	←	56 (1,430)
Tire		7.5-16 10PR	←	175R13 8PR
Net dry mass	lb (kg)	2,070 (940)	←	2,004 (910)
Operating mass	lb (kg)	2,290 (1,040)	←	2,225 (1,010)
●Compressor				
Free air delivery	cfm (m ³ /min)	185 (5.2)	166 (4.7)	185 (5.2)
Working pressure	psi (MPa)	100 (0.69)	←	←
Pressure of pressure control valve	psi (MPa)	58 (0.4)	←	←
Burst pressure of safety valve	psi (MPa)	150 (1.03)	←	145 (1.00)
Ambient conditions: temperature	°F (°C)	5-104 (-15 · +40)	←	←
Ambient conditions: altitude	yd (m)	less than 1,640 (1,500)	←	←
●Engine				
Type		NISSAN TD2714	←	←
Rated output	hp/min ⁻¹ (kW/min ⁻¹)	44.8/2,500 (33.4/2,500)	43.2/2,300 (32.2/2,300)	44.8/2,500 (33.4/2,500)
Fuel consumption	g/kW·h	288	279	←
Rated RPM	min ⁻¹	2,500	←	←
RPM at unload conditions	min ⁻¹	1,250	←	←
Net dry mass	lb (kg)	496 (225)	←	←
●Lubricating oils				
Engine oil capacity (high-low level)	gal.(L)	2.6-2.1 (10-8)	←	←
Compressor oil capacity (including receiver tank and oil cooler etc.)	gal.(L)	4.0 (15)	←	←
Compressor oil capacity to be filled		Ambient temperature 5°F-104°F (-15°C-+40°C)		
		HULS: ANDEROL 3032 MOBIL: RARUS SHC 1024 TEXACO: SYN-STAR DE32		MOBIL: RARUS 424 SHELL: CORENA OIL RS32 CALTEX: COMPRESSOR OIL RA32
Coolant capacity	gal.(L)	2.5 (9.5)	←	←
Fuel tank capacity	gal.(L)	25.1 (95)	←	←

1. Specification

Item	unit	PDS185S-6C1 (VE PUMP Type)		PDS185S-6C1R (IN LINE PUMP Type) for Asian countries
		for 55HP USA	for 49HP USA	
Emergency stop devices				
Actuating pressure of oil pressure switch	psi (MPa)	8.7 (0.06)		
Actuating temperature of water temperature switch	°F ()	more than 230 (110)		
Actuating pressure of discharge air temperature switch	°F ()	more than 248 (120)		
Fuel residual level gauge	gal.(L)	less than about 3.8 (14.5)		
Fuel filter drain	gal.(ml)	about 0.03-0.05 (120-170) to be drained		-
Fuel consumption ratio				
At full load (for reference only)	gal./Hr (L/Hr)	2.6 (10.0)		
At 70% load (for reference only)	gal./Hr (L/Hr)	1.9 (7.0)		
At 50% load (for reference only)	gal./Hr (L/Hr)	1.5 (5.5)		
At no load (for reference only)	gal./Hr (L/Hr)	0.9 (3.5)		
At no load (purge operation mode) (for reference only)	gal./Hr (L/Hr)	0.8 (2.9)		

1. Specification

1.2 Set Value

Item	unit	PDS185S-6C1 (VE PUMP Type)		PDS185S-6C1R (IN LINE PUMP Type) for Asian countries
		for 55HP USA	for 49HP USA	
Safety devices				
Discharge air temperature	°F ()	248 (120)		
Engine oil pressure	psi (MPa)	8.7 (0.06)		
Engine coolant temperature	°F ()	230 (110)		
Fuel residual level	gal.(L)	less than about 3.8 (14.5)		
Fuel filter drain	gal.(ml)	0.03-0.05 (120 ~ 170)		-
Set value				
Air filter differential pressure	psi (kPa)	0.9 (6.23)		
Pressure control valve	psi (MPa)	58 (0.4)		
Actuating pressure of safety valve	psi (MPa)	150 (1.03)		145 (1.0)
Unload starting pressure	psi (MPa)	100 (0.69)		
Engine RPM				
Rated RPM	min ⁻¹	2,500		
RPM at unload	min ⁻¹	1,250		
Indications of gauges or instruments during operation				
Discharge pressure gauge (at full load)	psi (MPa)	73-100 (0.5-0.69)		
Discharge pressure gauge (at no load)	psi (MPa)	104-131 (0.72-0.9)		
Discharge pressure gauge (at purge operation)	psi (MPa)	65-80 (0.45-0.55)		

1. Specification

1.3 Outline drawing

PDS185S-6C1 (VE PUMP Type)

Unit : in.

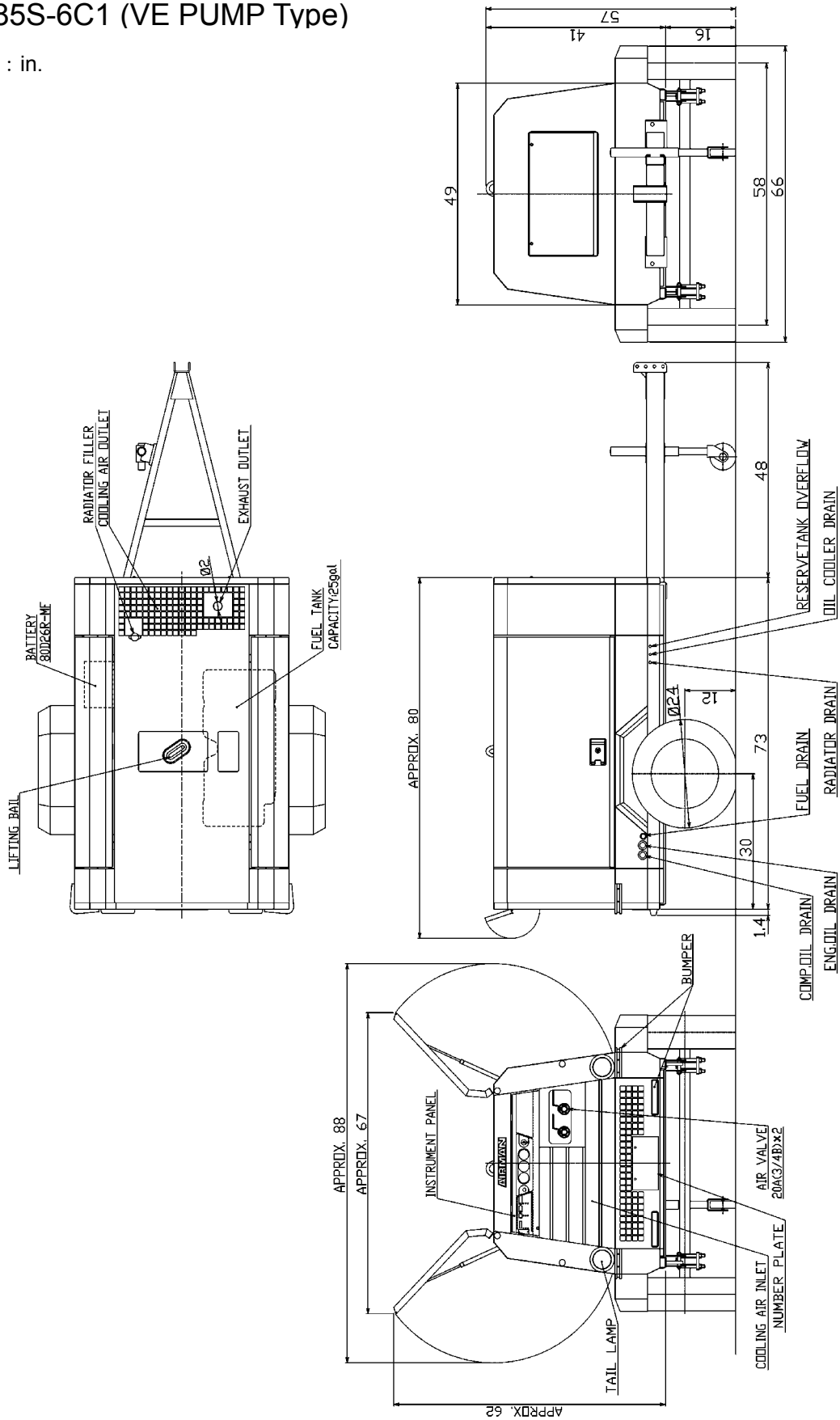

A070357

1. Specification

PDS185S-6C1 (VE PUMP Type)

Unit : mm

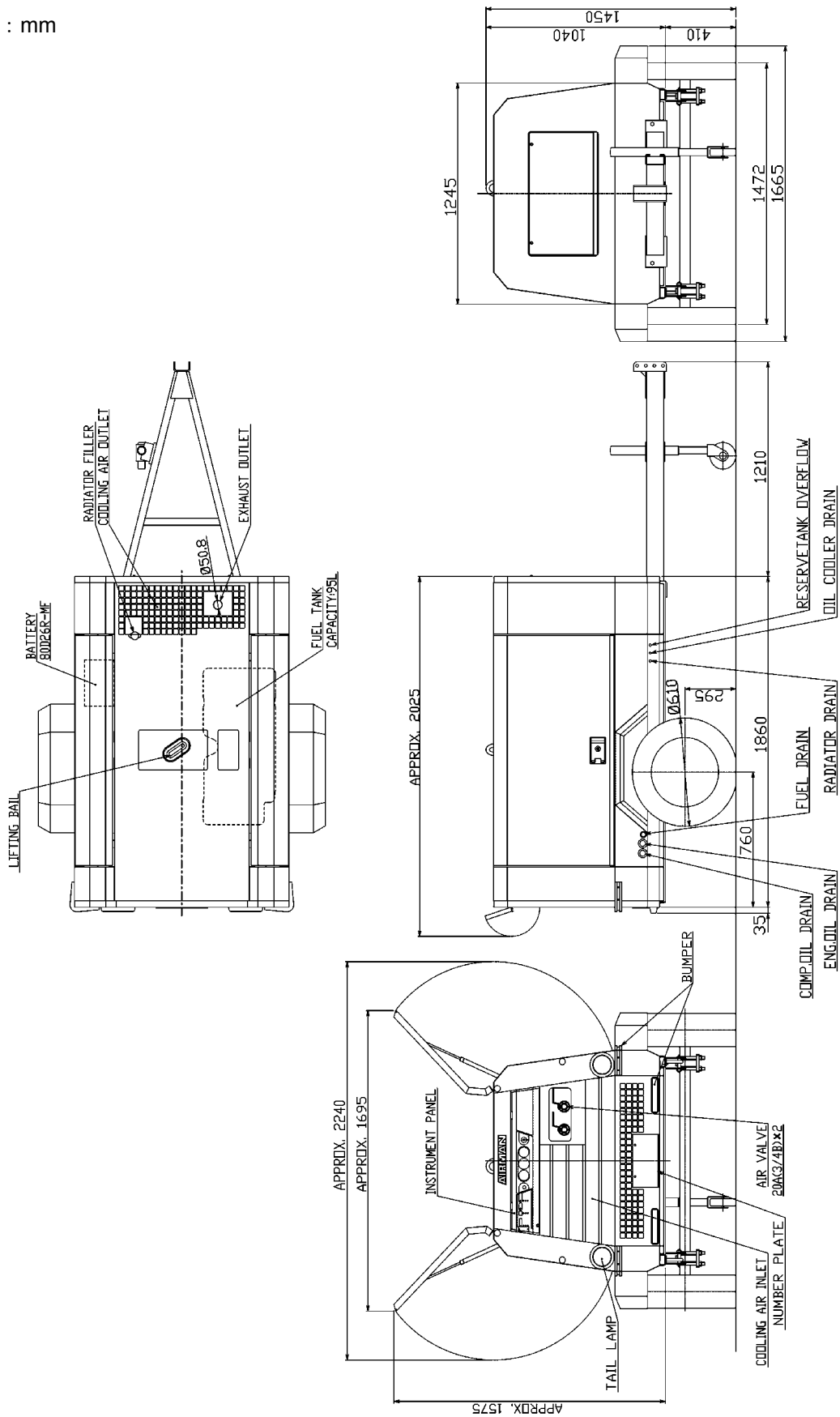

A070356

1. Specification

PDS185S-6C1R (IN LINE PUMP Type)

Unit : mm

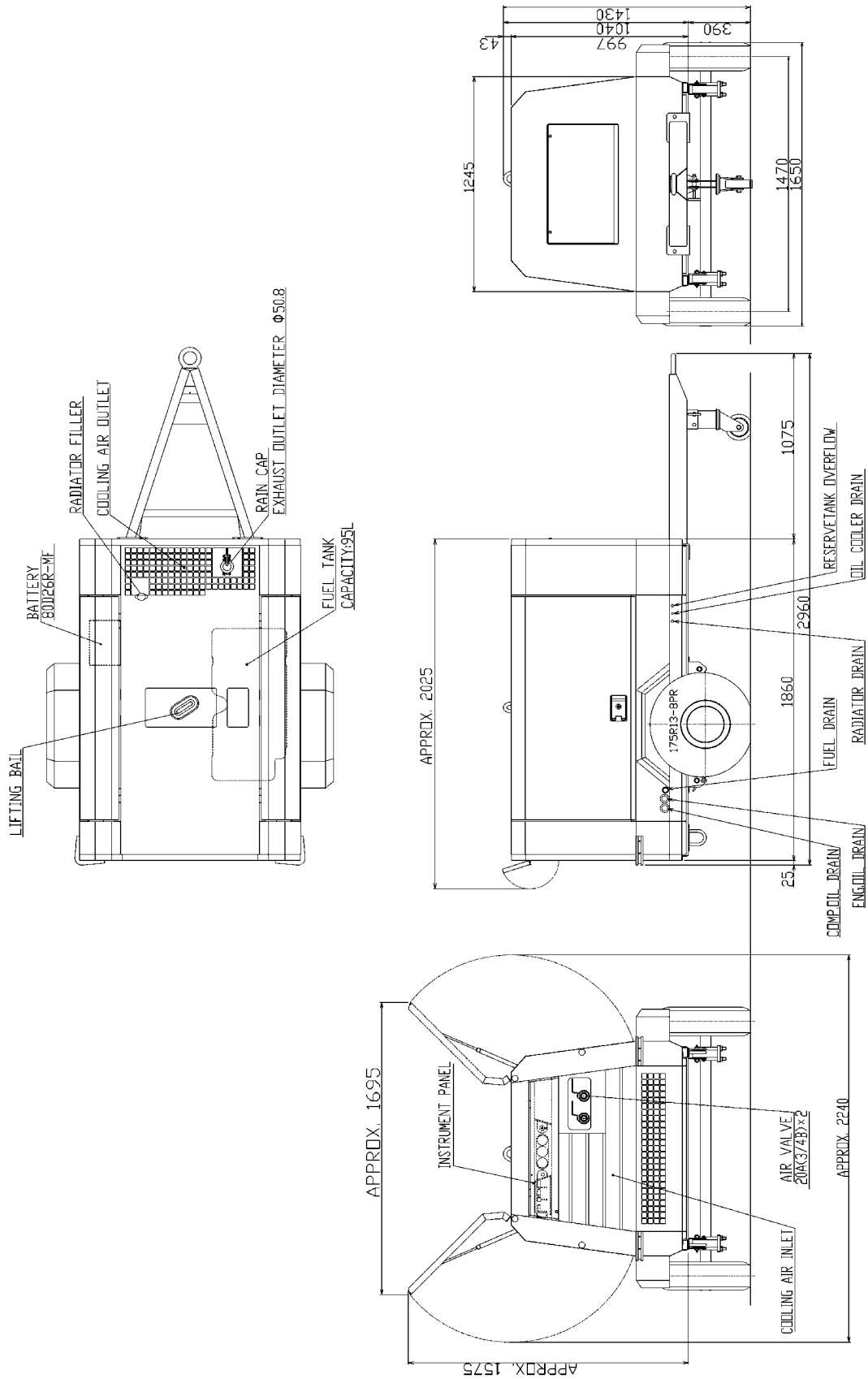

A070195E

1. Specification

1.4 Internal Components and Part Names

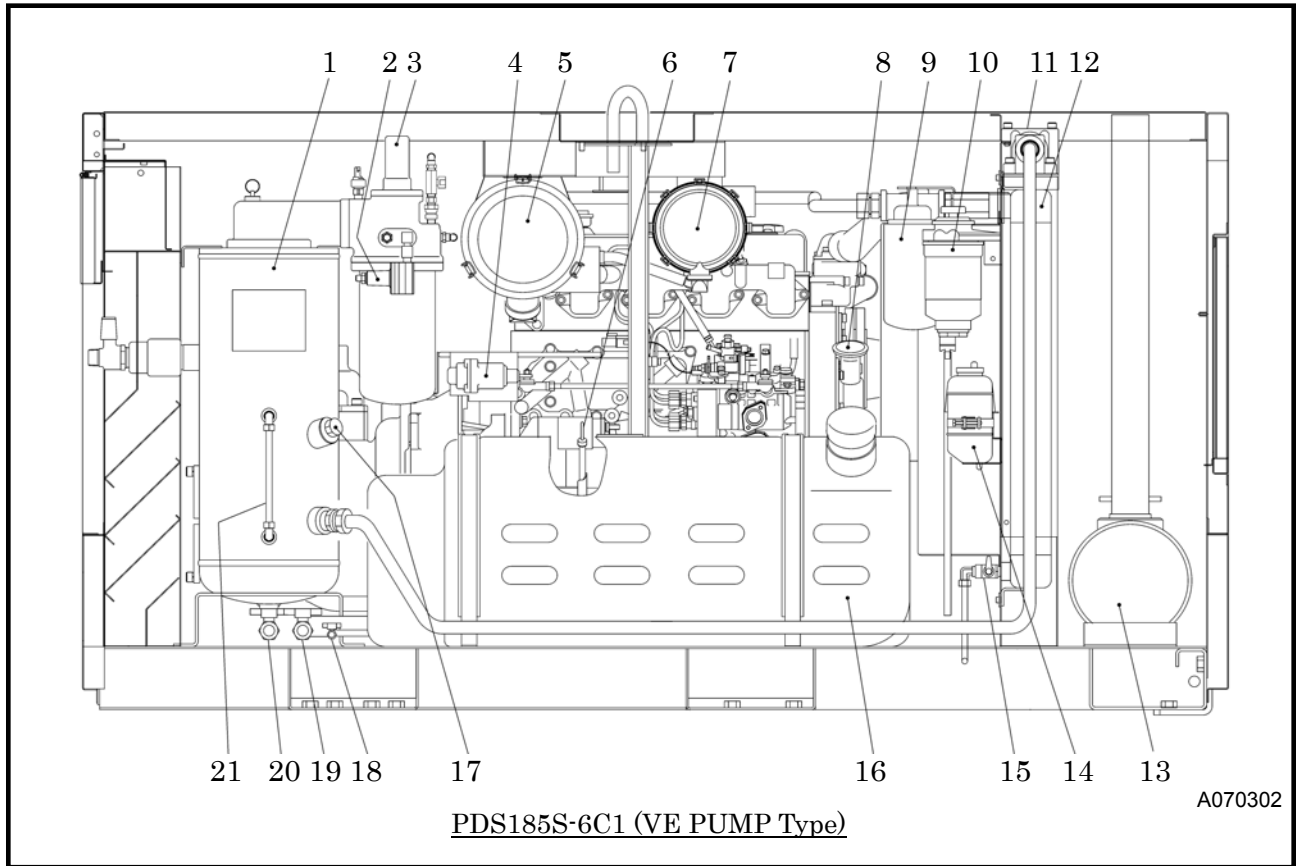

No.	Description	Function
1	Separator receiver tank	For separating compressor oil from compressed air sent into the tank.
2	Pressure regulator	For regulating intake air volume.
3	Pressure control valve	For keeping the receiver tank pressure higher than 58psi (0.4MPa) in the tank.
4	Speed regulator	For regulating engine revolution speed.
5	Air filter (For compressor)	For filtering the dust floating in the intake air.
6	Engine oil level gauge	For checking engine oil level.
7	Air filter (For engine)	For filtering the dust floating in the intake air.
8	Engine oil filler port	For supplying and replenishing engine oil to engine.
9	Compressor oil filter	For filtering compressor oil circulating in the system.
10	Fuel filter (sedimenter built-in type)	For filtering foreign matter mixed in fuel and separating water from fuel.
11	By-pass valve	For keeping compressor oil at proper temperature.
12	Oil cooler	For cooling compressor oil circulating in the system.
13	Exhaust muffler	Equipment which muffles an engine exhaust sound.
14	Reserve tank	For checking coolant level and supplying.
15	Oil cooler drain valve	For draining condensate accumulated at the bottom of oil cooler.
16	Fuel tank	For storing diesel fuel oil.
17	Compressor oil filler port	For supplying and replenishing compressor oil.

1. Specification

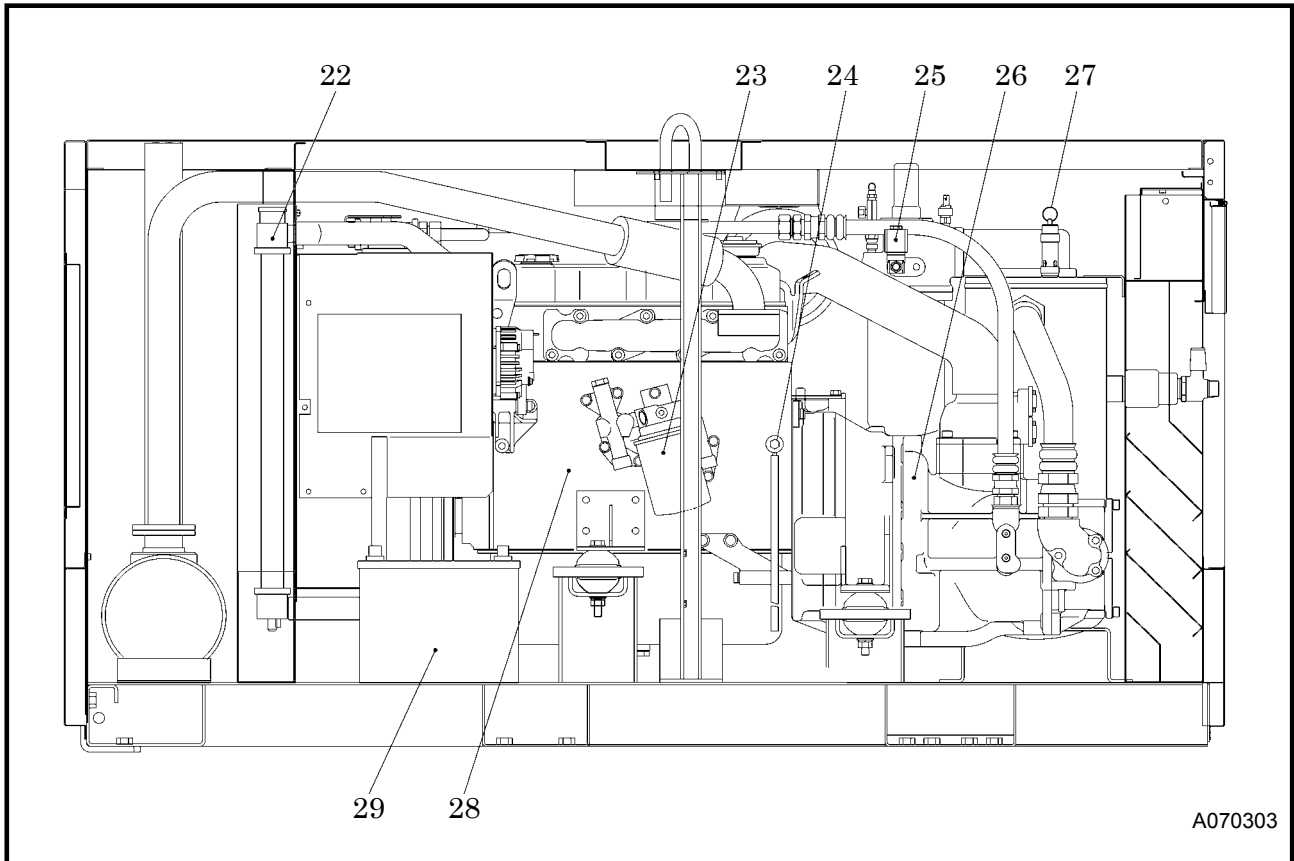

A070303

No.	Description	Function
18	Fuel tank drain valve	For draining condensate and water accumulated at the bottom of the fuel tank.
19	Engine oil drain valve	For draining engine oil for replacement of it and for maintenance.
20	Compressor oil drain valve	For draining compressor oil from separator receiver tank.
21	Compressor oil level gauge	Scale for measuring compressor oil level.
22	Radiator	For cooling the coolant for engine because it is water-cooled.
23	Engine oil filter	For filtering engine oil.
24	Coolant drain valve	For draining coolant from cylinder block.
25	Solenoid valve for AUTO IDLE mode	Control device for reduction of power under unloaded operation
26	Air-end	For compressing intake air.
27	Safety valve	For releasing compressed air to the atmosphere when the pressure rises higher than the rated pressure.
28	Engine	For driving the compressor.
29	Battery	For electrically starting engine.

1. Specification

1.5 Instrument panel

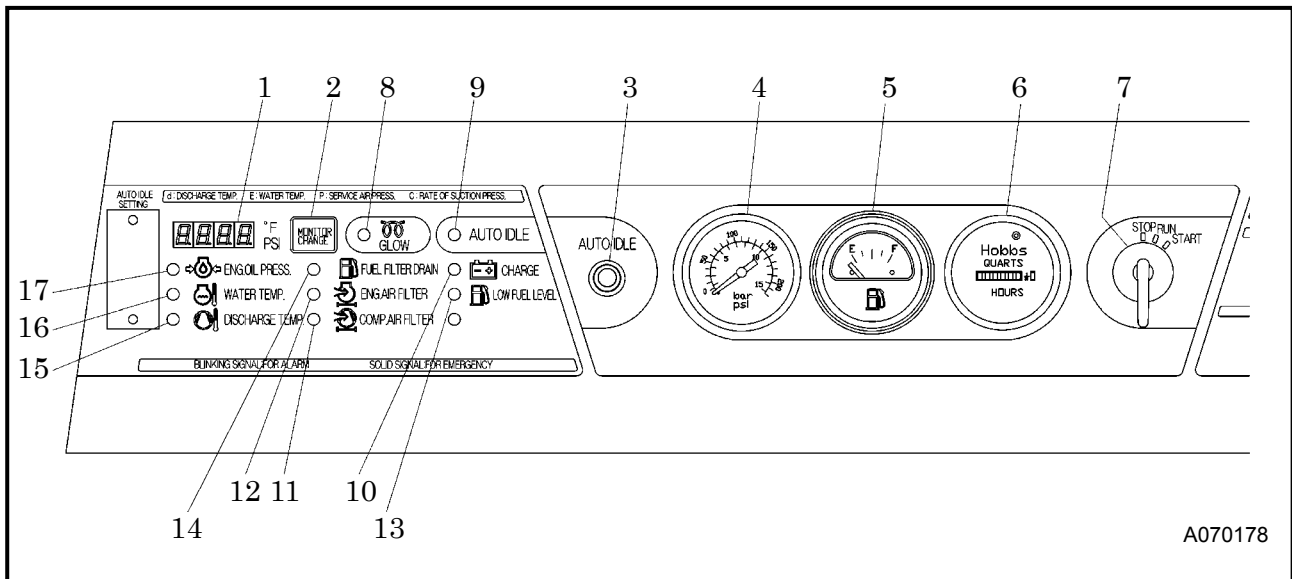

1. Digital monitor indicator (temperature/pressure)

2. Selector switch for digital monitor indication

3. Auto idle switch (Purge control)

4. Discharge air pressure

5. Fuel level gauge

6. Hour meter

7. Starter switch

<Indicator lamp>

8. Glow

9. Auto idle (Purge control)

<Warning lamp>

10. Charge

11. Compressor air filter clogging

12. Engine air filter clogging

<Emergency stop lamp>

13. Low fuel level

14. Fuel filter drain

15. Discharge air temperature

16. Engine water temperature

17. Engine oil pressure

1. Specification

1.5.1 Digital monitor indicator

- Place starter switch "ON" and then digital monitor indicator goes on.
- Press monitor selector switch for selection of digital monitor display.

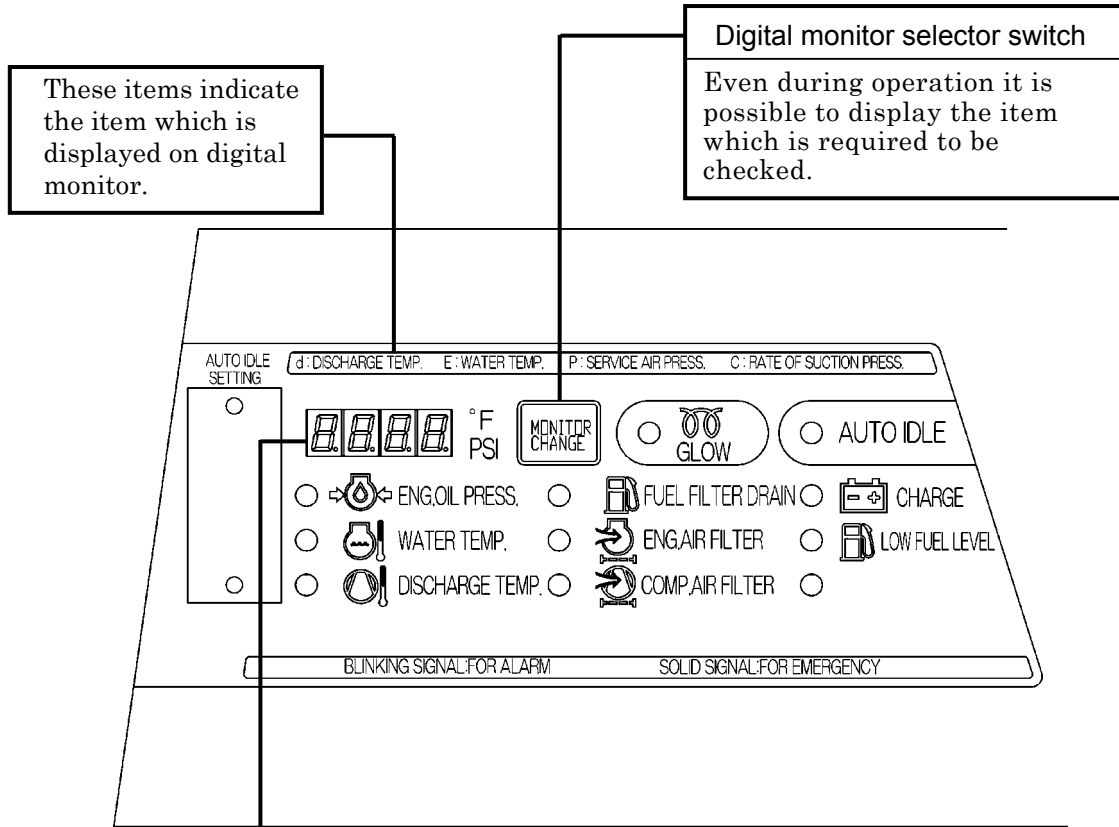

A070272-1

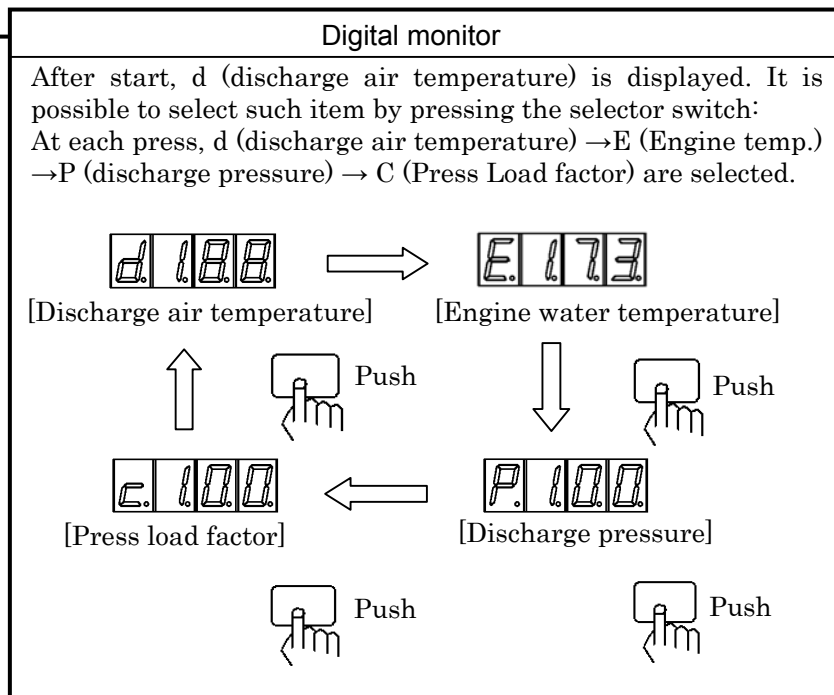

1. Specification

1.5.2 Indicator lamp

Indicator lamp



Turn the starter switch to “ON” position. Then the lamp will go on.

Item	Contents	Measures	Monitor
GLOW	Press starter switch “ON” and the lamp goes on and after preheating is finished, the lamp will be off.	—	
AUTO IDLE	AUTO IDLE Switch (Purge control) “ON” and then lamp goes on.	—	—

Warning lamp

When some little trouble occurs during operation, the lamp will go on.





When the warning lamp goes on, take appropriate measures to recover the situation swiftly.

Item	Contents	Measures	Monitor
CHARGE	Lamp goes on when alternator is not charging.	Check wiring. Check alternator.	
COMP. AIR FILTER	Lamp goes on when air filter gets clogged and suction resistance increases.	Clean Replace	
ENG. AIR FILTER	Actuating resistance is more than 0.9psi (6.23kPa).		

Emergency stop lamp

The compressor stops when the emergency stop lamp goes on.

Be sure to follow the measures shown below before starting the unit again.

Item	Contents	Measures	Monitor
LOW FUEL LEVEL	When fuel level in fuel tank drops and it becomes necessary to replenish fuel, the lamp goes on.	See “Troubleshooting”	
FUEL FILTER DRAIN	When fuel filter gets clogged with condensate inside, the lamp goes on.	Drain condensate	
DISCHARGE TEMP.	Lamp goes on when the air temperature at the outlet of the air-end reaches the set temperature of 248°F (120°C).	See “Troubleshooting”	
WATER TEMP.	Lamp goes on when coolant temperature reaches 230°F (110°C).		
ENG. OIL PRESS.	Lamp goes on when engine oil pressure drops. The function pressure is below 8.7psi (0.06MPa).		

1. Specification

1.6 Capacity Control Device

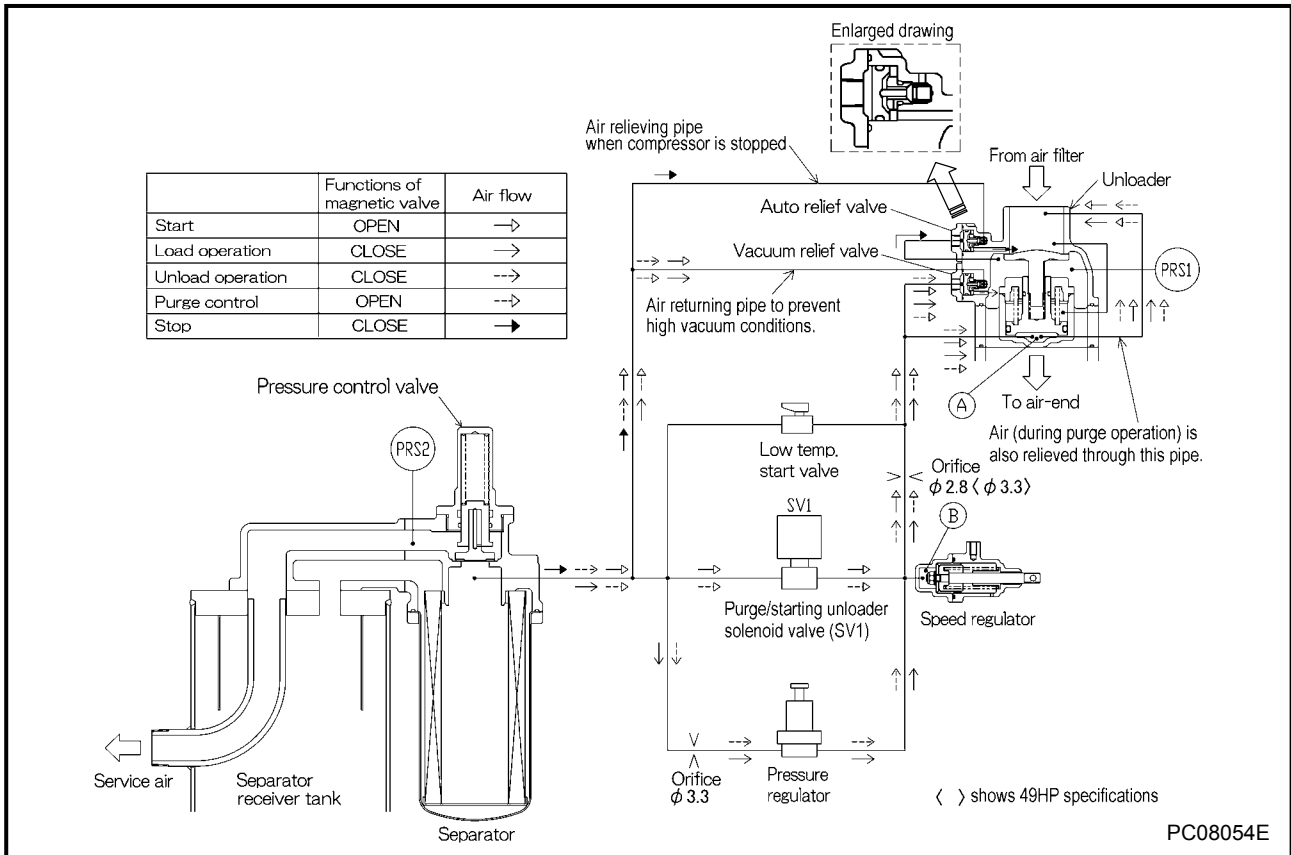

Step	Response
Start	When starting operation, purge/starting unloader solenoid valve (SV1) opens. And compressed air is sent to unloader chamber (A) and speed regulator chamber (B). The pressure in chamber (A) rises soon, and unloader valve fully closes due to low pressure. Thus the load required for starting is reduced.
Load operation	After starting operation, solenoid valve (SV1) closes after 10 seconds have passed. The air volume sent to the chambers (A) and (B) from pressure regulator increases or decreases according to the rise and drop of discharge air pressure. Thus according as unloader valve position and engine speed change, free air delivery is sleeplessly and automatically regulated from 0 to 100%.
Suction port closing unload operation	When air consumption is reduced, and the pressure exceeds the rated one, speed regulator functions to lower the engine speed in proportion to the pressure rise and, at the same time, to close unloader valve. Under unloaded operation, the interior of compressor air-end becomes vacuum and vacuum noise is caused. In order to prevent occurrence of vacuum noise, it functions to open the vacuum relief valve, detecting the secondary pressure of pressure regulator and thus it prevents high vacuum state inside the compressor air end from being caused.
Purge control unload operation	Intake negative pressure sensor (PRS1) detects the negative pressure inside compressor air end. When a certain set time has passed at lower pressure than the set negative pressure, solenoid valve (SV1) opens. Thus the compressed air in separator receiver tank is sent to compressor control line to close unloader valve and at the same time to relieve it from the tank to the atmosphere, lowering the pressure and saving compressor power. When air consumption increases and the pressure used for load drops below the set pressure, pressure sensor (PRS2) detects it and it disengages purge control mode (solenoid valve (SV1) closes) to start full load operation.
Stop	When stopping operation, it opens auto relief valve to relieve the compressed air in separator receiver tank to atmosphere, detecting the pressure inside compressor air-end.

1. Specification

1.6.1 AUTO IDLE control (Purge control)

This model is equipped with auto idle control operation mode. This operation mode is recommendable for such use: not so much air consumption is required and it is used continuously and also power consumption under unloaded operation is required to be saved. Use this mode, depending upon the need and demand. For the selection of this mode, switch on “AUTO IDLE” on the operation panel.

Select this operation mode freely, according to required air consumption.

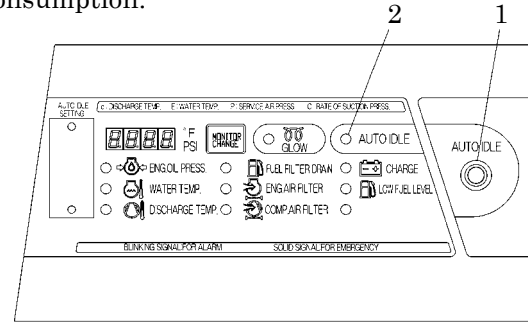

<Procedure>

- ① During operation, push on the switch “1” “AUTO IDLE”.
- ② Then the indicator lamp “AUTO IDLE” “2” goes on.
- ③ In order to stop this operation mode, push again “AUTO IDLE” switch “1” and then the lamp “2” goes out to disengage this purge mode.



A070184-1

[Function of AUTO IDLE control]

Function	Conditions of AUTO IDLE lamp
① When air consumption decreases, engine speed drops to the minimum with the function of pressure regulator and speed regulator. And when it decreases further, the unloader valve closes gradually to raise intake negative pressure. Negative pressure sensor (PRS1) detects this rising negative pressure. Then when the intake negative pressure becomes higher than the set pressure, purge operation timer functions to make “AUTO IDLE” lamp flicker in short intervals.	When purge timer functions  Lamp flickers at short intervals.
② When this condition continues for a certain time, the purge/starting unloader solenoid valve (SV1) for purge mode functions to start purge mode operation. Consequently, the pressure inside separator receiver tank drops and reduces the power of compressor air end. In this stage, the lamp “AUTO IDLE” flickers at longer intervals.	Purge operation  Lamp flickers at longer intervals.
③ When air consumption increases and the pressure used for consumer side drops below the purge releasing pressure, purge/starting unloader solenoid valve (SV1) gets “OFF” and it is transferred to normal operation. “AUTO IDLE” lamp changes from flickering to lighting on.	At load operation under auto idle control mode  Lamp goes on.

1. Specification

1.6.2 Setting of "AUTO IDLE" control (purge control) pressure/timer

[Standard set values prior to delivery ex-works]

Item	Set prior to delivery ex-works	Setting range
Purge releasing pressure VR3	80psi (0.55MPa)	50-95psi (0.35-0.66MPa)
Purge starting intake negative pressure VR2	30%	0-80%
Timer set to be expected for purge mode VR1	10 seconds	10-112 seconds

CAUTION

- Purging mode operation is already arranged prior to delivery from factory. Therefore, it is not necessary to perform any adjustment in usual case.
- For adjustment of VR1, VR2 and VR3, follow the under-mentioned procedures.
- For adjusting set value with knob, turning the knob to left lowers the set value, while turning the knob to right raises the value.

<Procedure>

- ① Remove the cover "1".
- ② Place the starter switch "ON".
- ③ At first keep pressing digital monitor selector switch "2" for 5 seconds.
- ④ Then, digital monitor "P" flickers. Adjust the purge release pressure (VR3) to the set pressure value.
- ⑤ When pushing digital monitor selector switch "2" after having completed setting of VR3, the digital monitor "C" flickers. Then adjust the purge starting suction pressure (VR2) to the set value.
- ⑥ When pushing digital monitor selector switch "2" after having completed setting of VR2, the digital monitor "T" flickers. Then adjust the time (VR1) for purge mode operation to the set value.
- ⑦ When pushing the digital monitor selector switch "2" after having completed setting it, the digital monitor returns to display discharge air temperature.
- ⑧ Install the cover "1" after having completed setting operation mode.

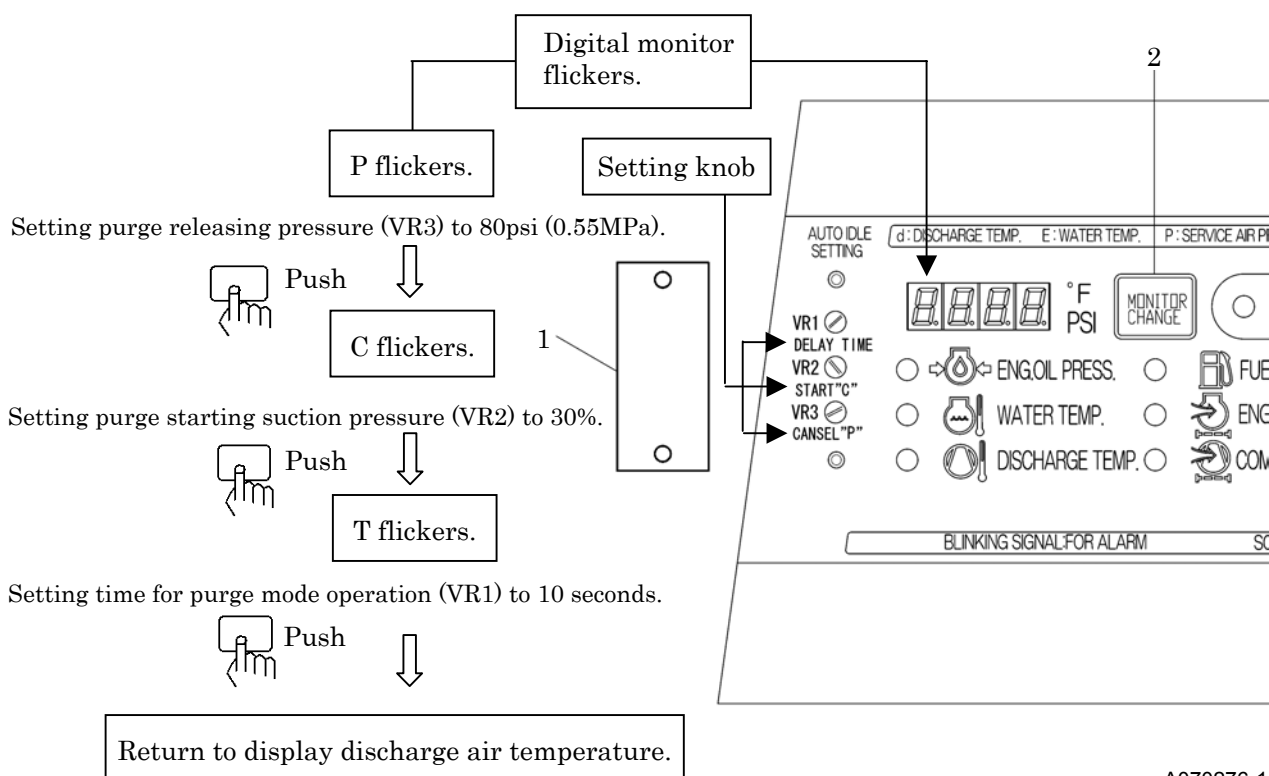

A070276-1

1. Specification

1.7 Piping Diagram

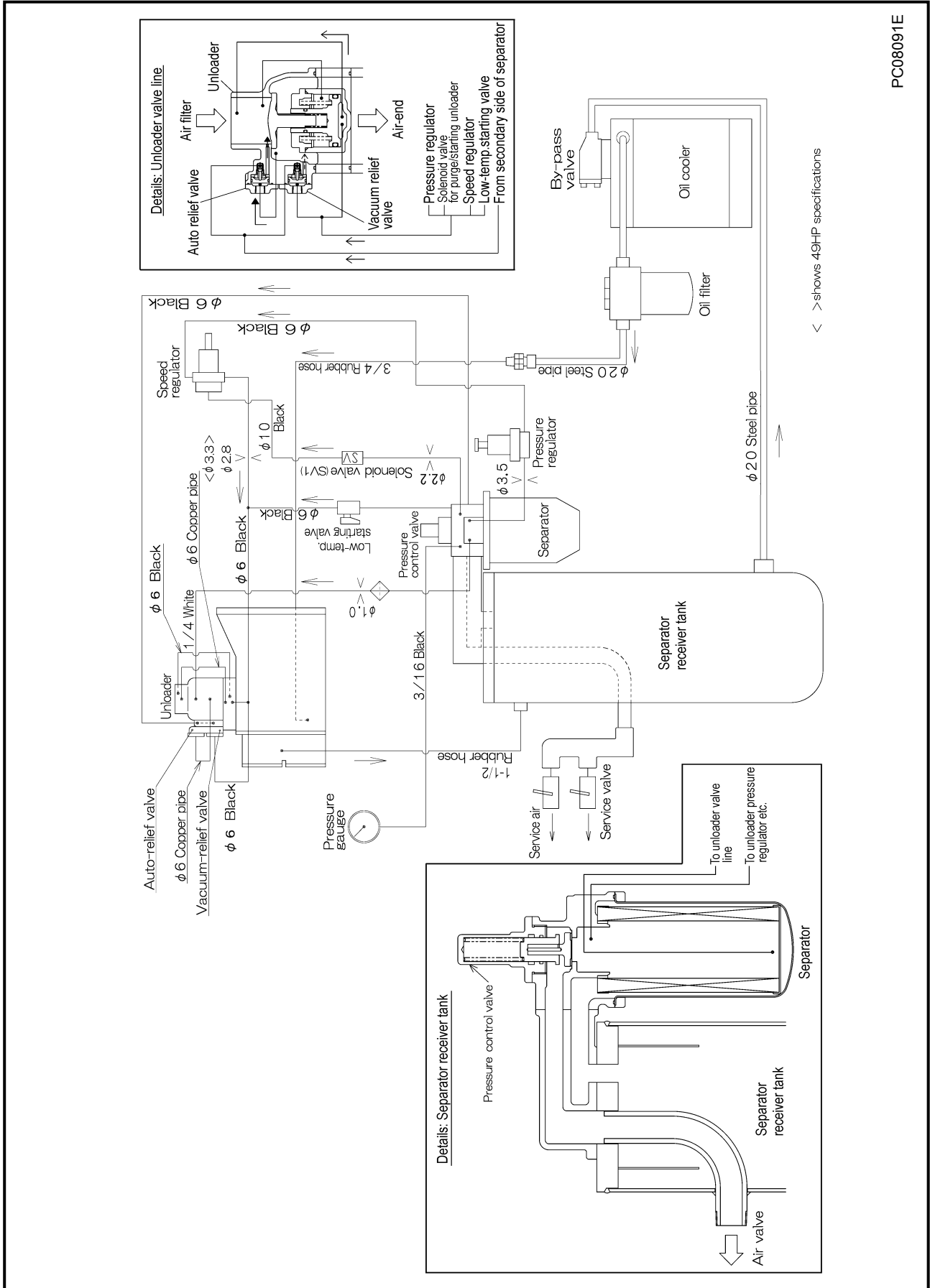

PC08091E

1. Specification

1.8 Fuel piping

PDS185S-6C1 (VE PUMP Type)

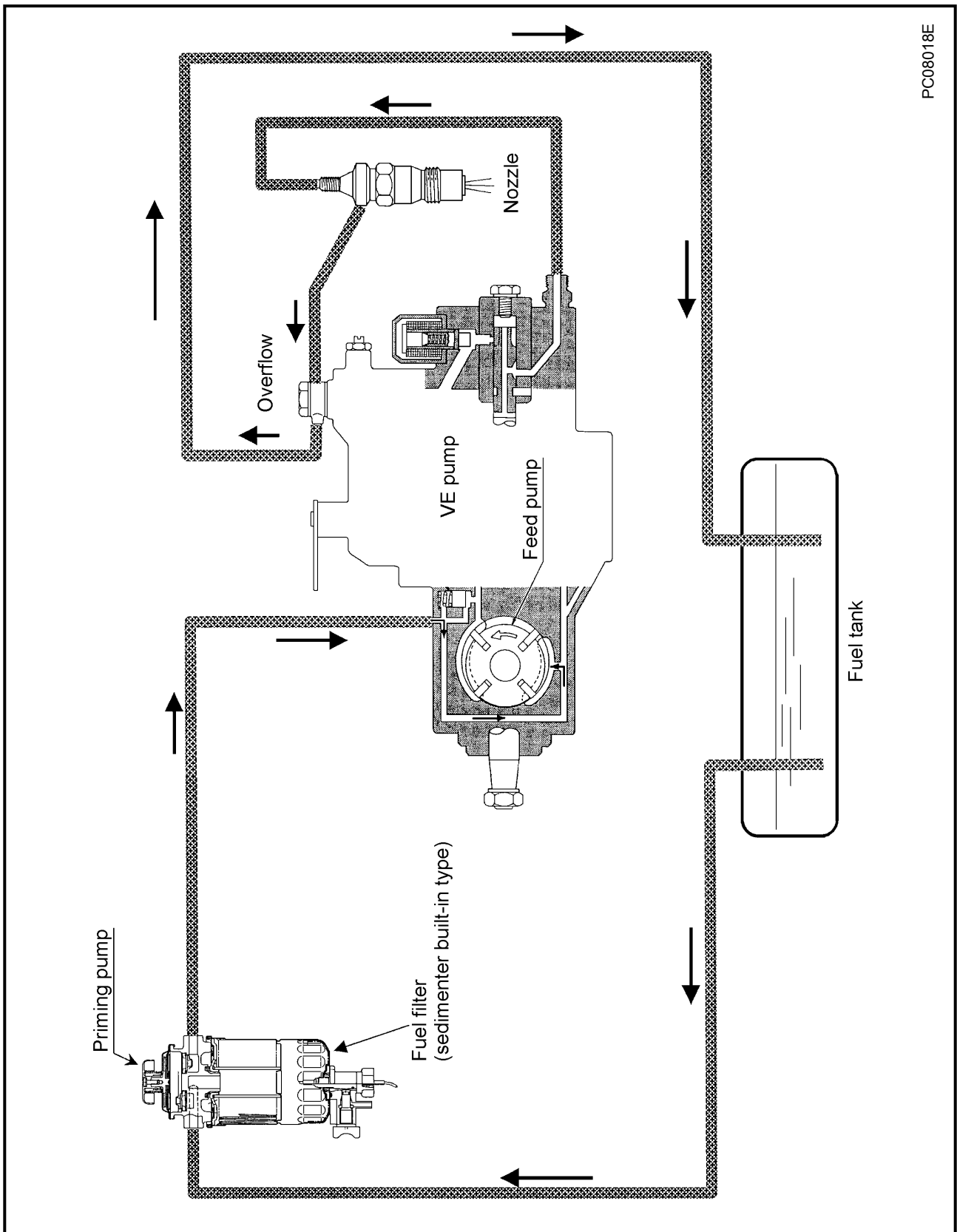

1. Specification

PDS185S-6C1R (IN LINE PUMP Type)

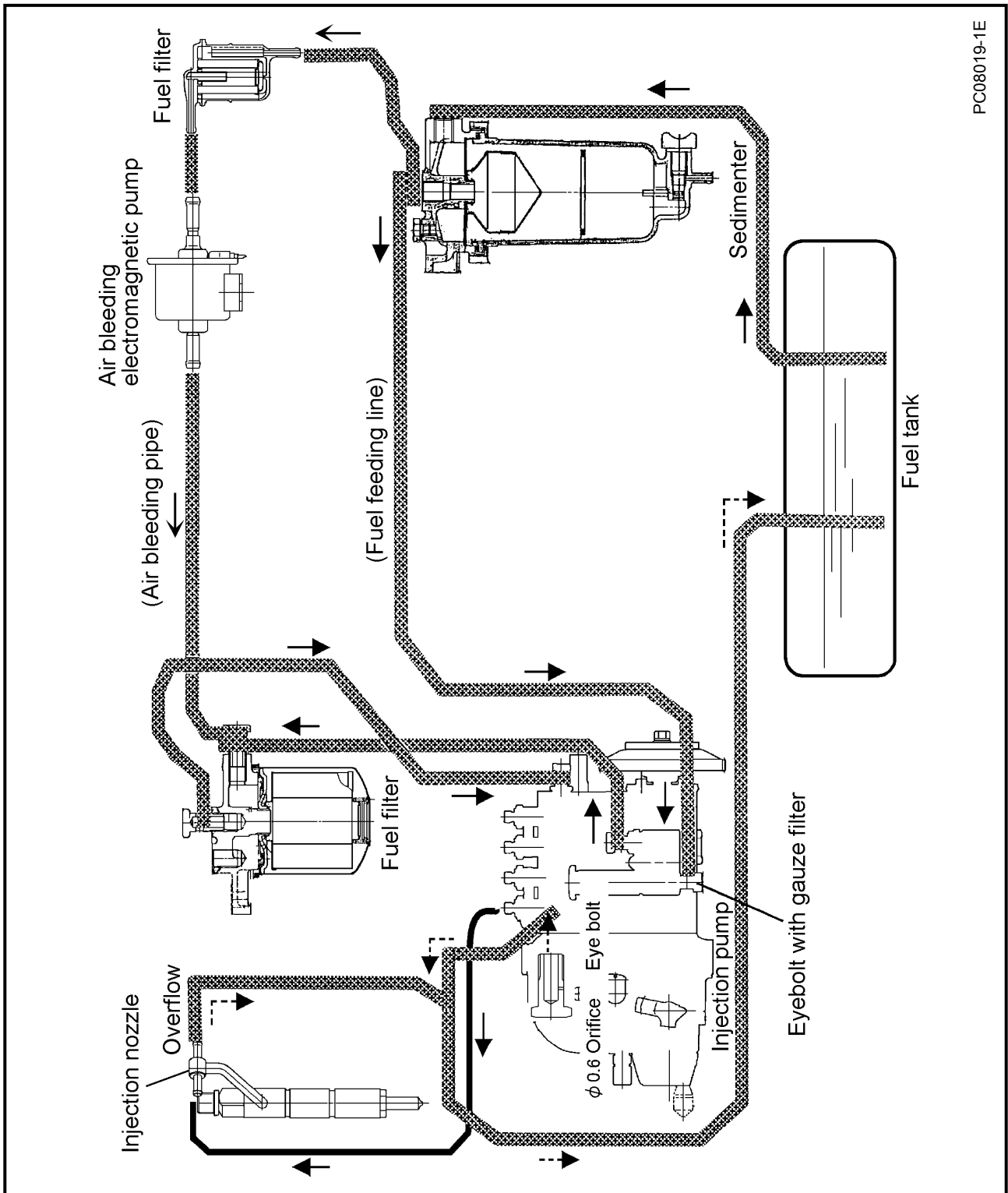

PC08019-1E

2. Maintenance

2.1 Cautions for Overhauling

2.1.1 Precautions before starting work

(1) Work to be performed

It is very important to always plan in advance what facilities, tools, instruments, materials, oil, etc. you will need to use; the exact locations and methods of performing inspection, adjustment, or disassembly; and the key points of any repair work to be performed.

(2) Care not to spill oil

Use a pan to collect used compressor oil, engine oil when changing the oil or attaching or detaching an oil line. If a large volume of oil is expected to flow out make, sure to drain any accumulated oil from the reserve tank, engine oil pan in advance.

(3) Care when detaching parts

When disassembling a complicated part, put a matching mark to indicate the position of detached parts for future reference. Make sure that the negative cable is detached from the battery terminals before starting repair work.

(4) Tools to be prepared

① Measuring instruments (e. g. tester, insulation resistance gauge etc.)

② Tools

③ Torque wrenches

④ Jigs and specialized tools

⑤ Sealing tape

⑥ Molybdenum sulfide (tube type)

⑦ Lithium extreme pressure type grease (CALTEX MULTIFAK EP1)

⑧ Diesel oil

⑨ Compressor oil

⑩ Cleaning cloths

⑪ Literatures (such as manuals etc.)

2.1.2 Disassembly and assembly

(1) Before removing nylon tubes, hydraulic/fuel hoses, it is necessary to clean the inside of machine to prevent from entrance of dirt and foreign matters.

(2) Perform disassembly work in a dust-free location whenever possible.

(3) When disassembling parts, wash their outer surfaces and place them on a clean sheet of paper or cloth, taking care not to contaminate or damage them.

(4) Wash disassembled parts with diesel oil (cleaning solvent) after checking for contamination or discoloration. However, do not wash rubber parts with diesel oil.

(5) Be careful not to damage disassembled parts, they are precision built.

(6) Replace consumables such as oil seals, O-rings, filters, oil, etc. with new items when reassembling parts.

(7) Install O-ring and oil seal which should be coated with clean lithium extreme pressure type grease (CALTEX MULTIFAK EP1).

(8) When reassembling parts, place each part in the order of assembly and take care that no parts are missing or misassembled.

(9) When reassembling an assembled part (set part), be sure to replace it as an assembly.

(10) Contamination or rusting may occur due to dust or humidity if parts are left in disassembled or partly disassembled condition for a long time. Therefore, be careful to prevent dust or rust from affecting parts if you have to leave the repair incomplete for a long period of time.

(11) Check tightening torque and clearance when assembling parts.

(12) Check the direction of rotation, speed, and oil leakage after assembly.

(13) Before starting the machine after disassembly, run it at low idle to check for unusual noises, etc. to prevent engine or generator damage.

2. Maintenance

2.2 Tightening torque

General bolts and nuts tightening torque

Fasten all the bolts and nuts with the specified tightening torque when assembling.

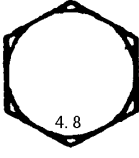
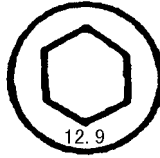
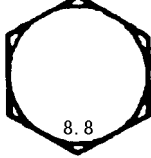
Kind	Low or Middle carbon steel bolt (SS400B etc...)		High tensile strength bolt (SCM435 etc...)		
	4.6~6.8 (4T~6T)		8.8~12.9 (7T~12T)		
Strength and sorting	 Hexagon bolts		  Socket bolts Hexagon bolts		Tightening torque lbf·in. (kgf·cm)
Width of across flat· Tightening torque					
Bolt diameter in.(mm)	Hexagon bolts Width of across flat in.(mm)	Tightening torque lbf·in. (kgf·cm)	Socket bolts Width of across flat in.(mm)	Hexagon bolts Width of across flat in.(mm)	Tightening torque lbf·in. (kgf·cm)
0.24 (6)	0.39 (10)	44 (51)	0.20 (5)	0.39 (10)	87 (100)
0.31 (8)	0.51 (13)	108 (124)	0.24 (6)	0.51 (13)	213 (245)
0.39 (10)	0.67 (17)	213 (245)	0.31 (8)	0.67 (17)	421 (485)
0.47 (12)	0.75 (19)	370 (425)	0.39 (10)	0.75 (19)	734 (845)
0.55 (14)	0.87 (22)	586 (675)	0.47 (12)	0.87 (22)	1172 (1350)
0.63 (16)	0.94 (24)	916 (1055)	0.55 (14)	0.94 (24)	1823 (2100)
0.71 (18)	1.06 (27)	1260 (1450)	0.55 (14)	1.06 (27)	2517 (2900)
0.79 (20)	1.18 (30)	1780 (2050)	0.67 (17)	1.18 (30)	3560 (4100)
0.87 (22)	1.26 (32)	2430 (2800)	0.67 (17)	1.26 (32)	4861 (5600)
0.94 (24)	1.42 (36)	2995 (3450)	0.75 (19)	1.42 (36)	6163 (7100)
Applied sections.	For general sections such as bonnet and frame.		For specified sections.		

IMPORTANT

- Generally, the abovementioned tightening torques should be followed, but in some points different torque is specified. So use the tightening torque without fail. (See following pages.)
- Make sure to remove rust and dust before tightening.

2. Maintenance

2.3 How to adjust regulator and how to replace diaphragm

2.3.1 Method of adjustment



CAUTION — Operation with compressed air supply port opened is prohibited

- When adjusting regulator system, install a silencer to the air delivery port and wear earplugs for protection of hearing damage.

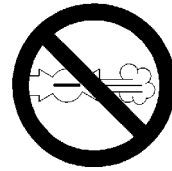

D003

- The speed regulator is already adjusted prior to delivery ex.works. Never change the setting of the regulator by turning bolt and rod recklessly.
- If it is necessary to re-adjust the speed regulator due to overhauling or any trouble, adjust it in accordance with the following procedures.

PDS185S-6C1 (VE PUMP Type)

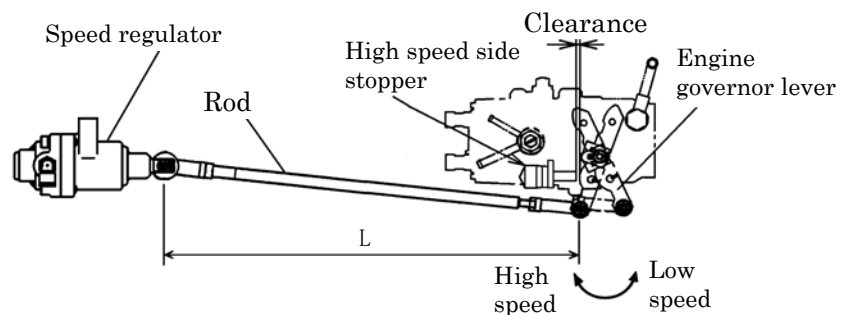
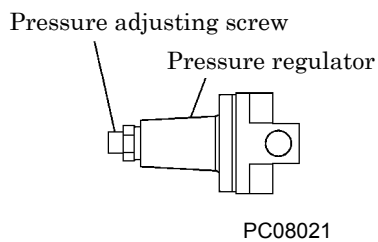

<Adjustment procedure> (For engine speed and pressure, see 1.2)

- ① Adjust the length of the rod connecting speed regulator so that engine governor lever can be pulled toward high speed side, with compressor kept stopping. (Making the rod length short, engine speed increases.)

Make adjustment so that such a little clearance which will never touch each other should be reserved between the high speed side stopper and engine governor lever. With both stopper and lever kept in contact, power will be loaded on the shaft of lever side to cause damage and trouble. But it is not necessary to adjust unloaded operation speed.

- ② Adjust this system so that when unload starting pressure exceeds 100psi (0.69MPa) by turning pressure adjusting screw, speed regulator can start to function to lower engine RPM. (Tightening the screw, the pressure rises, and loosening it, the pressure drops.)

2. Maintenance

PDS185S-6C1R (IN LINE PUMP Type)

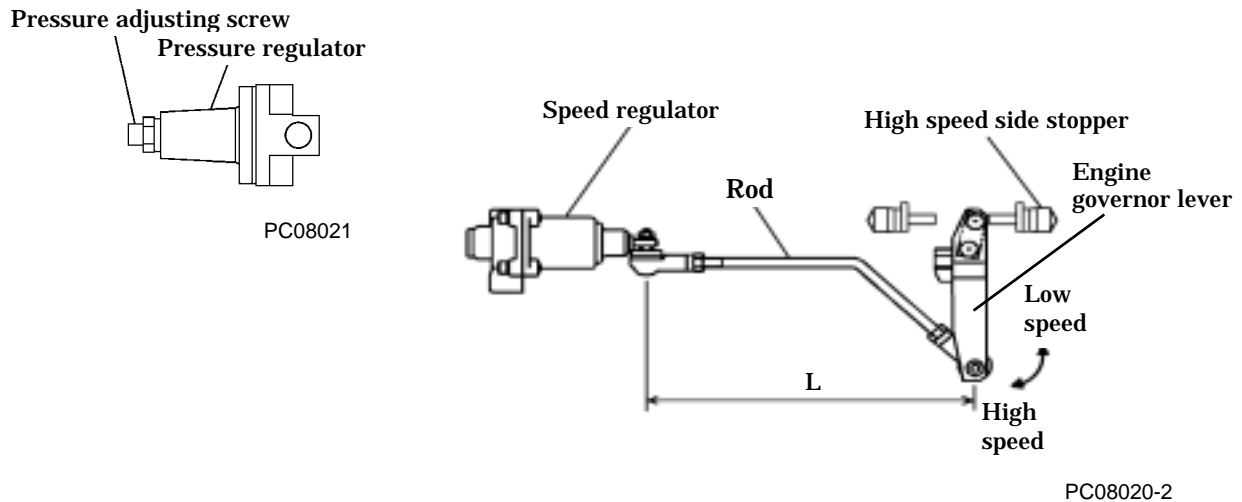

< Adjustment procedure > (For engine speed and pressure, see 1.2)

Adjust the length of the rod connecting speed regulator so that engine governor lever can be fully pulled toward high speed side, with compressor kept stopping. (Making the rod length short, engine speed increases.) If engine governor lever does not touch high speed side stopper, it is impossible to get a determined engine speed at full load operation. But it is not necessary to adjust unload operation speed.

Adjust this system so that when pressure exceeds 100psi (0.69MPa) by turning pressure adjusting screw, speed regulator can start to function to lower engine RPM. (Tightening the screw, the pressure rises, and loosening it, the pressure drops.)

IMPORTANT :

Make sure to adjust engine speed in accordance with the above adjustment procedure so that engine governor lever can touch high speed side stopper at full load operation. When separator receiver tank pressure drops below 65.3psi (0.45MPa) at unload operation with engine speed set lower than rated set speed, discharge air temperature rises and it will result in a serious trouble.

2. Maintenance

2.3.2 Change Diaphragm

Speed Regulator (Bellophragm type)

<Procedure>

- ① Remove the speed regulator from the bracket and disassemble it.
- ② Replace diaphragms with new ones.
- ③ Check A to D shown in figure for any burrs.
- ④ Diaphragm is delivered in different state from the state in which it should be installed. So install diaphragm which should be turned inside out, as shown in the following Fig.

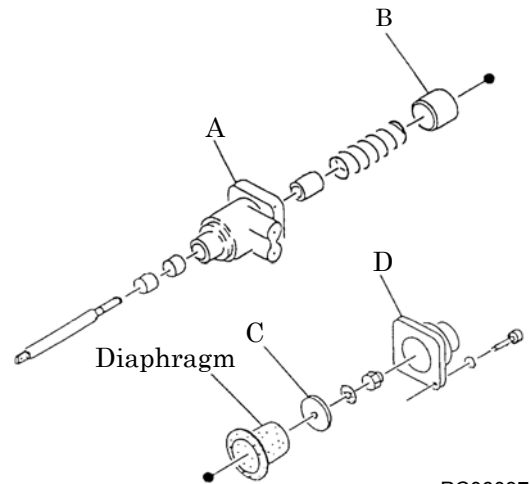

PC06037

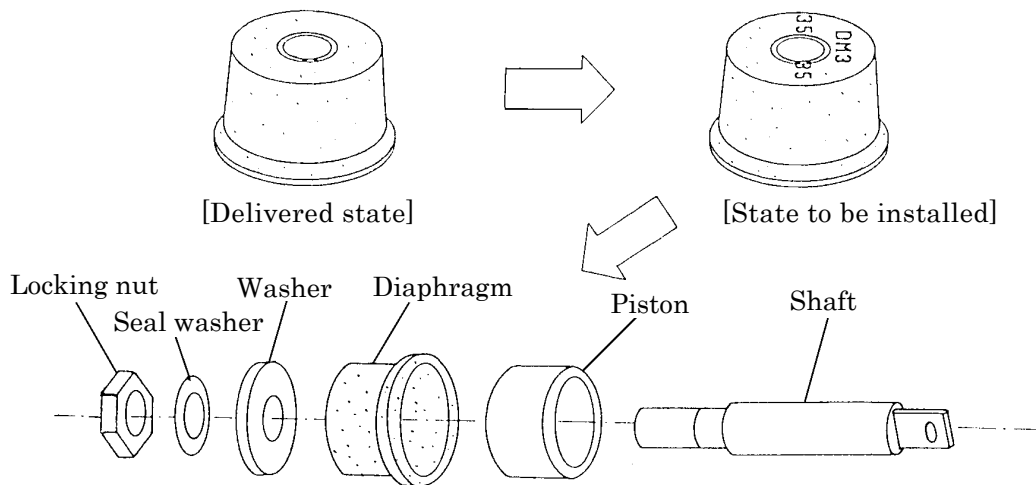

- ⑤ Internal face of body and cap and also both internal face and external face of diaphragm should be coated with molybdenum oxide spray.

How to spray molybdenum oxide paste : The areas in oblique line should be sprayed with this paste.

Diaphragm should be rolled up and back face and piston should be sprayed.

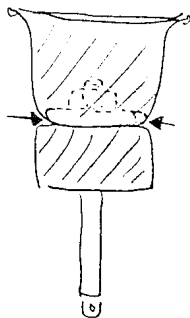

Then it should be returned and be sprayed.

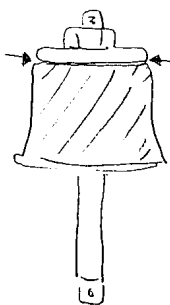

Inside of body should be sprayed.

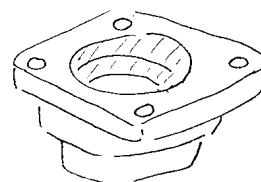

Inside face of body should be sprayed till middle line.

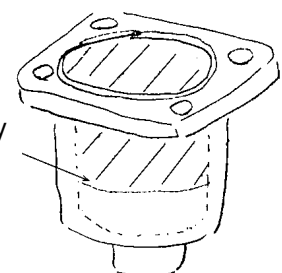

※ Jointed portion should be sprayed enough.

2. Maintenance

- ⑥ Install diaphragm to shaft and piston and fasten it with a locking nut.

Tightening torque : 69.4 lbf·in. (80 kgf·cm)

Important : Be careful not to tighten the locking nut excessively. Excessive tightening can cause washer to turn together and twisting diaphragm. The diaphragm will be damaged in shorter period.

- ⑦ Put in diaphragm to be settled equally in the body using an assembly tool.

Important : Once diaphragm is settled in, turn slowly the tool for secure installation. When turning the tool, hold the diaphragm not to be afloat.

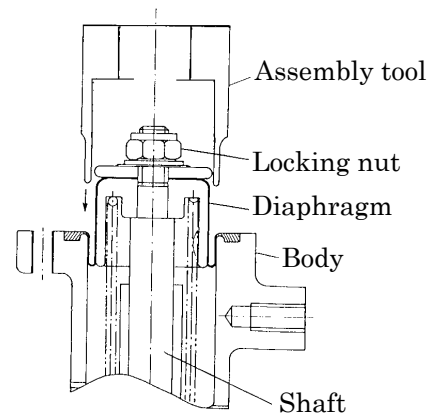

- ⑧ After diaphragm is set in, install the cap and then assemble speed regulator.

Important : Before installing the cap, make sure again that the portion of diaphragm shown in right figure is seated intact. If diaphragm is afloat, it can cause diaphragm to be caught in when installing cap. If the shaft is turned after installation is finished, it could damage diaphragm. Take care.

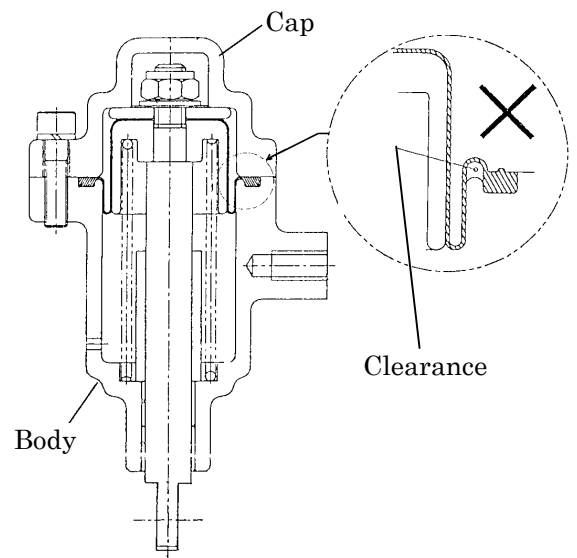

- ⑨ After re-assembling the speed regulator, adjust it according to the adjustment method of speed regulator (See 2.3.1)

2.4 Clean the strainer provided inside the engine feed pump (PDS185S-6C1R IN LINE PUMP Type only)

- Regularly take off the strainer “1” from engine feed pump and wash it.
- Remove the strainer “1” by loosening the joint bolt and clean it with diesel fuel oil, and also using high air pressure blow. At this time be sure to replace gasket. Then after finishing all cleaning jobs, install it again in reverse steps.

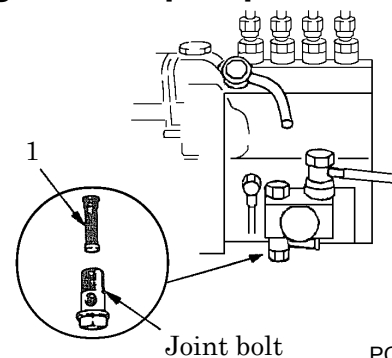

PC08056

2. Maintenance

2.5 Clean the strainer provided inside the sedimenter (PDS185S-6C1R IN LINE PUMP Type only)

- Regularly take off the strainer “1” in the sedimenter and wash it.

< Procedure >

- ① Remove the sedimentor cup “2” .
- ② Turning the bracket “3” , remove the strainer “1” .
- ③ After washing the strainer “1” with diesel oil, remove foreign matter by blowing with high pressure air.
- ④ After finishing cleaning, install all the disassembled parts in reverse order.

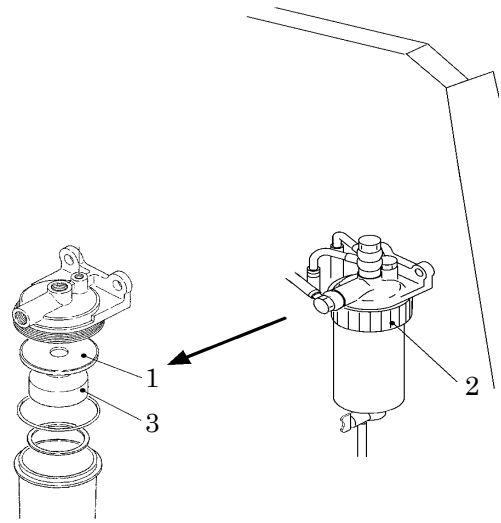

2.6 Change fuel filter (sedimenter built-in type) (PDS185S-6C1 VE PUMP Type only)

< Procedure >

- ① Separate the sensor connector “1” (provided at the lower part of fuel filter) from the main wiring portion.
- ② Loosen the drain valve “2” and then drain condensate and residual fuel staying inside the filter into a container etc.
- ③ Remove the cartridge “4” from the cover “3” , using a filter wrench.
- ④ Remove the sensor assembly “5” from the cartridge “4” .
- ⑤ Install the sensor assembly “5” to the new cartridge “4” .
- ⑥ New cartridge “4” please bind tight using a filter wrench.
- ⑦ After finishing the installation, install the removed connector “1” to where it was.
- ⑧ Finally, press the priming pump “6” up and down a few times for air bleeding in fuel line. Continue it till the pump moves heavily.

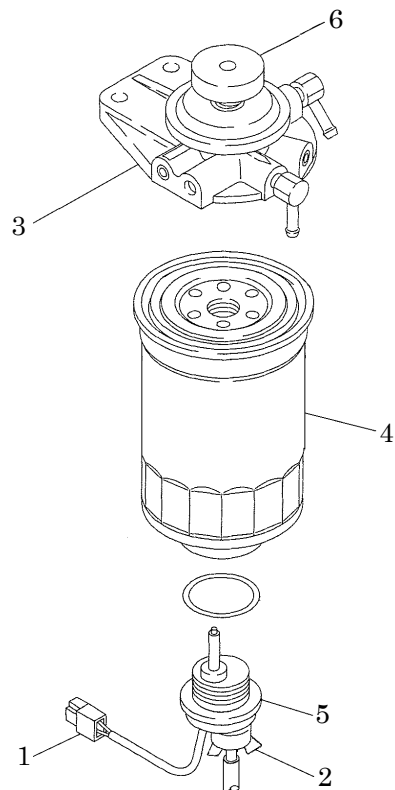

A070305

2. Maintenance

2.9 Check O-ring and Needle valve of Auto-relief valve and Vacuum relief valve

- Disassemble and clean the component, and check O-ring “1”, “2”, “3” and needle valve “4”. Then, replace O-ring “1”, “2”, “3” and rubber on the needle valve “4”, if hardened.

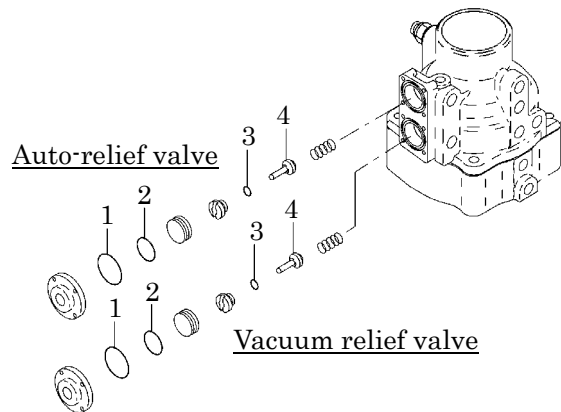

PC08057

2.10 Performance check of Pressure control valve

IMPORTANT

- When reassembling, apply sufficient grease to O-ring Slot/O-ring and sliding surface. Use CALTEX MULTIFAK EP1 grease or equivalent. Grease of poor quality will deteriorate the material.

<Procedure>

- ① When closing stop valve and fully opening service valve while the machine is running, make sure that the discharge pressure gauge shows the figure between 49-68psi (0.34-0.47MPa).
- ② When the pressure is lower than 49psi (0.34MPa), replace spring “3” with a new one.
- ③ When the indicator shows excessively higher pressure, you will find that the piston does not move smoothly due to foreign material and rust stuck inside valve. In such a case, disassemble the component for checking and cleaning.

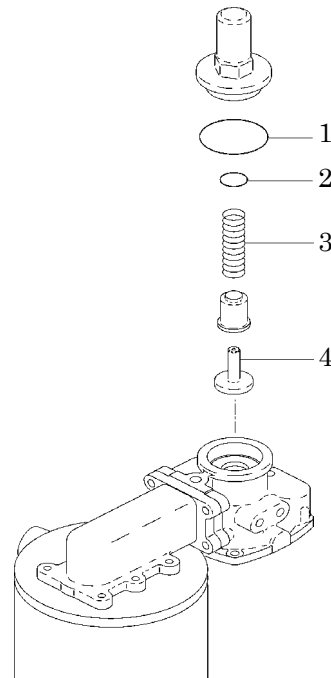

A070338

2.11 Check Pressure Control Valve O-Ring and Piston

- Disassemble and clean the component, and check O-ring “1”, “2” and the piston “4” shown in 2.9 then, replace it, if they are hardened.
- After replacement, run the machine to check its function, air-leak or any disorder.

2. Maintenance

2.12 Clean inside of Fuel Tank

- Condensate is caused and accumulated at the bottom of fuel tank, owing to churning of dust or dirt mixed when fuel oil is fed and water drop caused while fuel oil tank is used for a long time. When any condensate is found afloat and fuel filter gets clogged too fast, fuel oil tank should be cleaned after condensate is removed from fuel oil tank even before the specified cleaning interval time.

<Procedure>

- ① Open drain valve to remove fuel oil from fuel tank.
- ② Dismantle the door and side covers of bonnet.
- ③ Remove fuel pipes and wires connected to fuel tank.
- ④ Remove belt holding fuel tank and remove tank.
- ⑤ Insert cleansing nozzle through fuel filler port or drain port for cleaning tank.
- ⑥ After cleaning job is finished, install fuel tank from which water or the like should be completely removed.

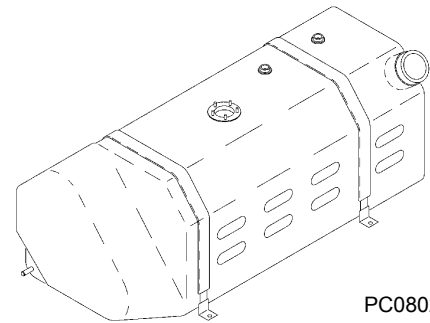

2.13 Change of pellet assembly of by-pass valve

- By-pass valve fitted on this unit is of full bore type. While the unit is used for normal operation, it is not to perform periodical replacement of the Inner pellet assembly, but when such trouble as excessive rise of compressor oil temperature, it becomes necessary to replace it, in accordance with the following procedures.

<Procedure>

- ① First stop the unit and make sure that there is no residual pressure left in the separator receiver tank.
- ② After checking and confirming that the temperature of compressor oil has become amply low, open drain valves on separator receiver tank and oil cooler to empty compressor oil completely.
- ③ After having drained oil completely, remove the pellet assembly of by-pass valve and O-ring.
- ④ Replace the pellet assembly and O-ring by new ones. Install O-ring coated thinly with compressor oil.
- ⑤ Supply compressor oil through the filler port provided on the receiver tank. (Refer to operation manual.)
- ⑥ Start operation and check the function of by-pass valve. (It functions well when delivery air temperature will not rise abnormally.)

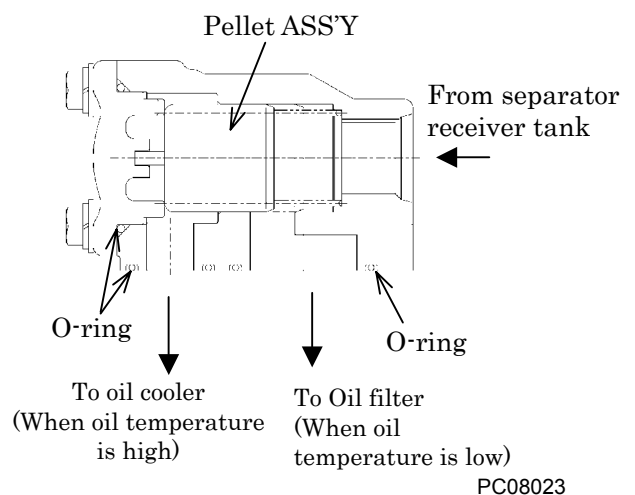

Actuating temperature	By-pass valve fully closing temperature
180 ± 37°F (82 ± 3°C)	192 ± 36°F (89 ± 2°C)

2. Maintenance

2.14 Values of Various Adjustments of Engine

Item		unit	PDS185S/185S-6C1R	
Engine model			NISSAN TD2714	
Tightening torque of head bolts		lbf·in. (kgf·cm)	First time	434-521 (500~600)
			Second time	868-955 (1000~1100)
Valve clearance	Air intake	in.(mm)	0.014 (0.35) (in warm season)	
	Discharge	in.(mm)	0.014 (0.35) (in warm season)	
Firing order			1-3-4-2	
Injection timing (BTDC)		°	5	
Nozzle injection pressure		psi (MPa)	1422 (9.81)	
Compression	Standard	psi (MPa)	427 (2.94) (Rotation speed 200min ⁻¹)	
	Working limit	psi (MPa)	Limited value	356 (2.45)
			Each cylinder limit value	43 (0.29)
Thermostat	Temperature for start of release	°F (°C)	160 (71)	
	Full open temperature	°F (°C)	185 (85)	
	Valve lift	in.(mm)		

3. Electric System

3.1 Engine electric appliances

3.1.1 VE PUMP

The engine mounted on PDS185S-6C1 is equipped with VE type injection pump. VE pump has been developed to be small, light-weighted, high speed injection pump. They are mainly mounted on diesel cars and small trucks.

■ Structure of VE pump

In-line pump needs each one plunger for each cylinder of engine, but VE pump has one metering plunger regardless of the number of engine cylinders, and this turns reciprocally to meter fuel to each cylinder. Governor, timer and feed pump are incorporated in the pump body. For this reason, compared with inline pump, it has less parts and further small sized and light-weighted.

■ Excellent performance

1. Excellent gas emission performance

When VE pump is used for same type swirl chamber engine, NO_x gas is emitted less compared with inline pump. (Fluctuation among cylinders is reduced because of one set plunger only used.)

2. Excellent reliability

VE pump has been originally developed to be used for diesel engine cars. Small sized inline pump runs 4,000min⁻¹, but VE can run 6,000min⁻¹ maximum.

When this engine is used for comparably lower speed industrial machines, the machine reliability increases in addition to less spare parts required and simple construction.

3. Engine noise is reduced

VE pump has one plunger regardless of numbers of engine cylinders. Fuel is fed by one plunger, injection volume is metered smoothly. As fluctuation of engine fuel injection is reduced, and especially under low load operation, engine noise can be cut remarkably.

■ Special attention during operation

VE pump can be lubricated interiorly with fuel filled, so when bad quality fuel is used, it could cause trouble to engine. As for fuel, use diesel fuel oil (having higher than 45 cetane number).

3. Electric System

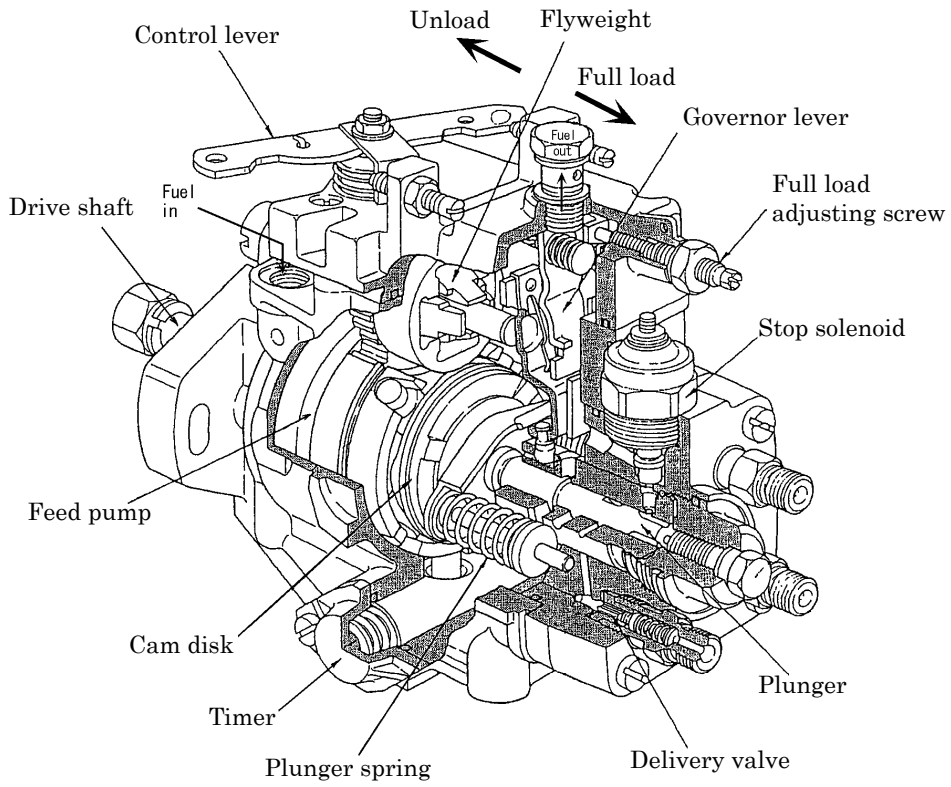

PC08024

Structure of VE pump

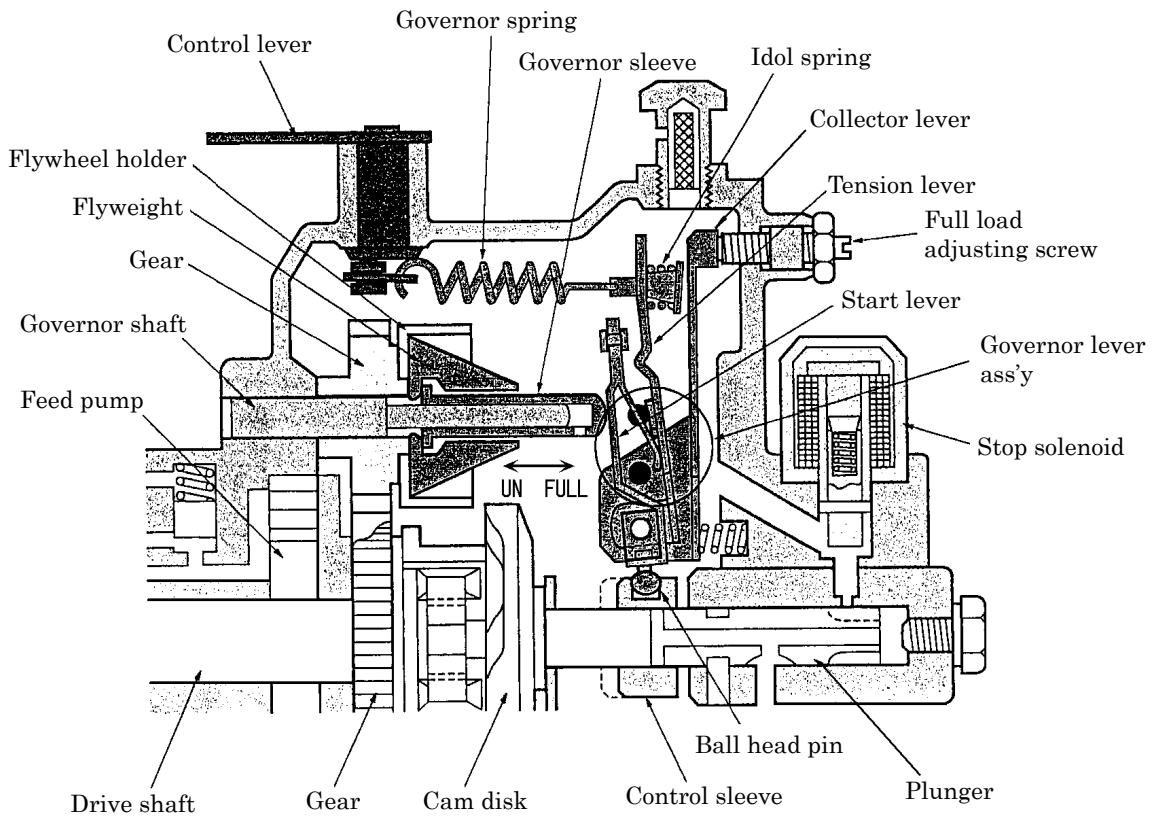

PC08025

3. Electric System

3.1.2 Control

Part number:46879 41400(PDS185S-6C1 : VE PUMP Type for USA)

Part number:46879 45700(PDS185S-6C1R: IN LINE PUMP Type for Asia)

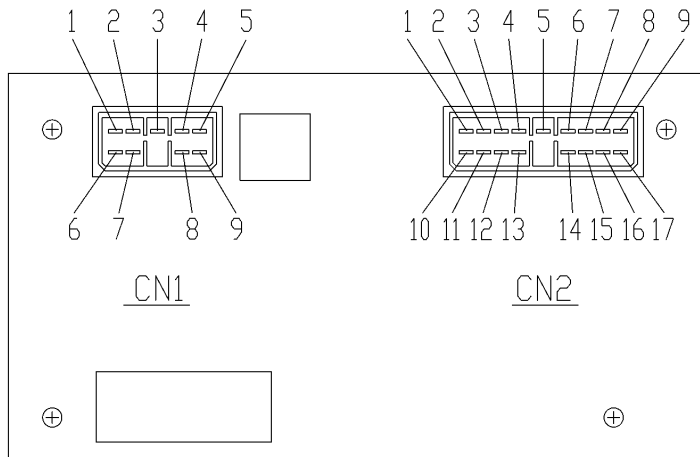
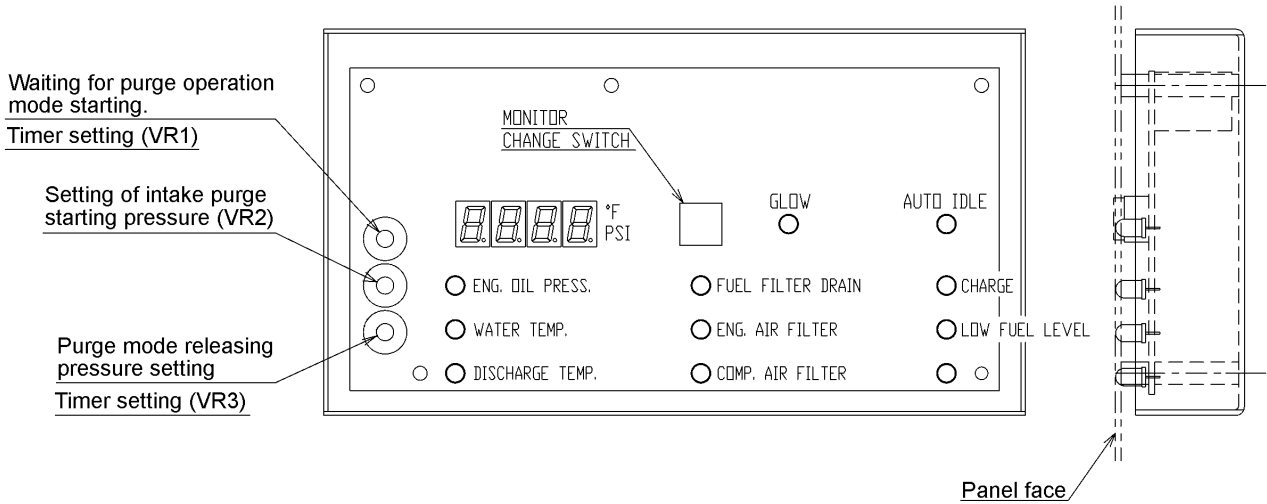

PC08026E

3. Electric System

1. Exterior connection drawing

(1)PDS185S-6C1(VE PUMP Type)

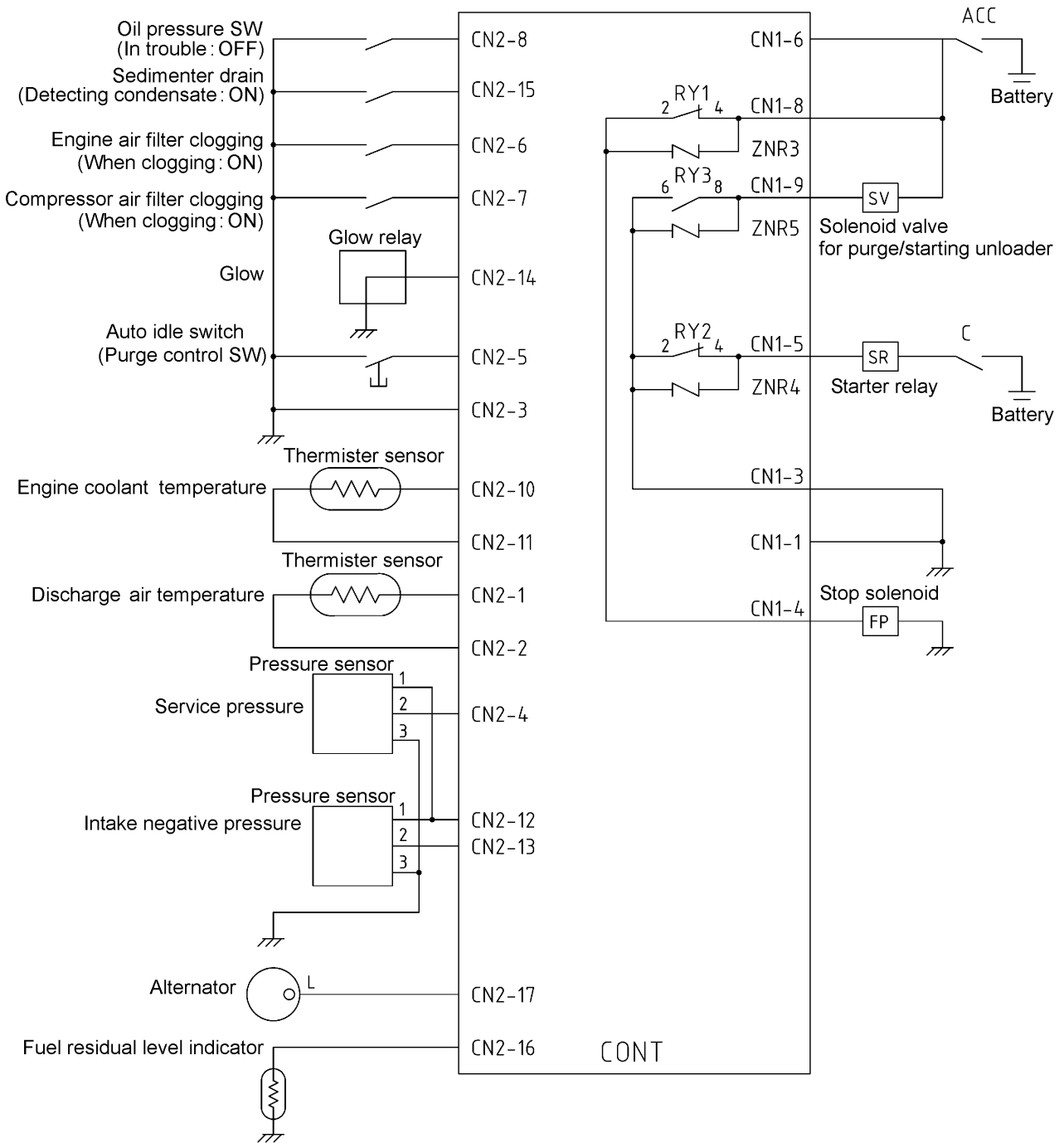

PC08027E

3. Electric System

(2)PDS185S-6C1R (IN LINE PUMP Type)

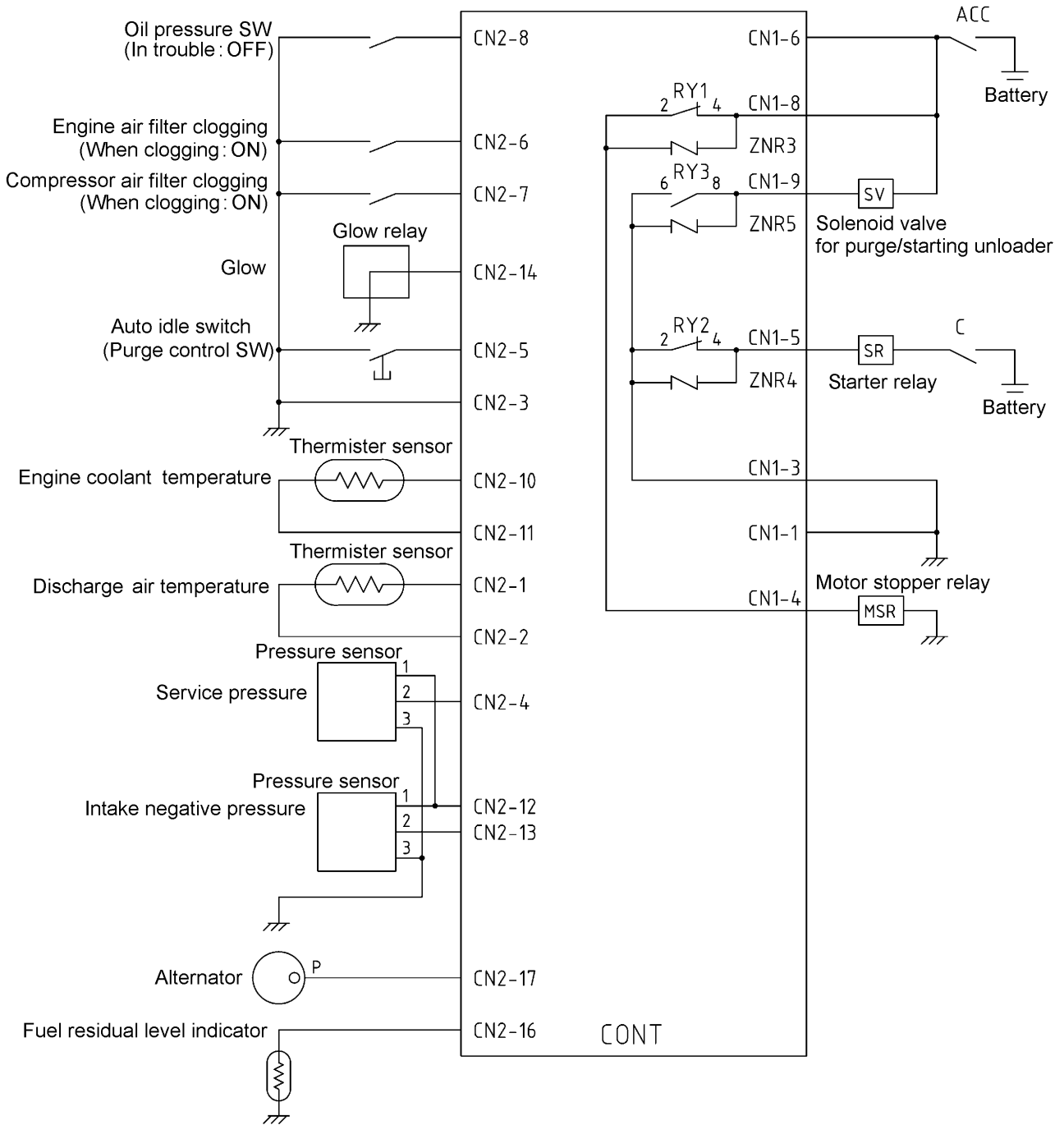

PC08028E

3. Electric System

2. Function timing upon starting

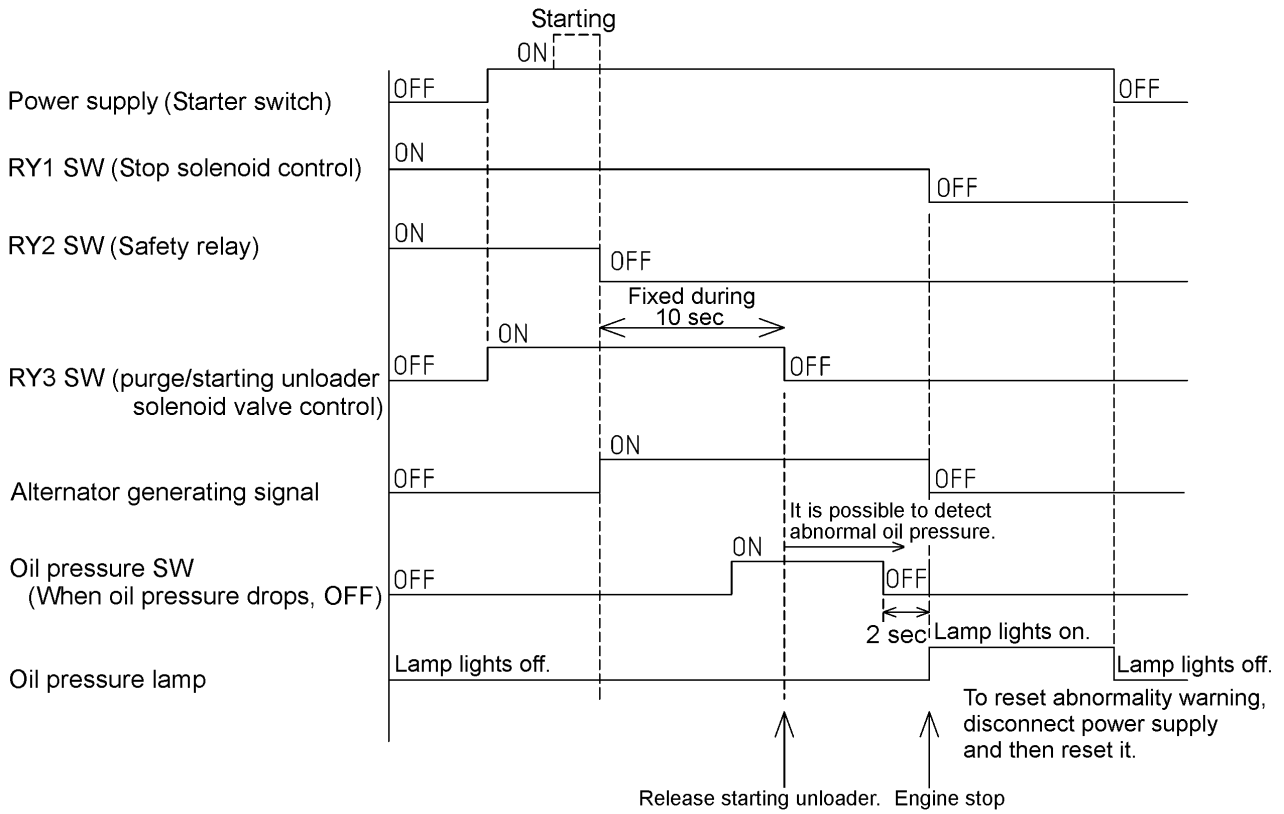

PC08029E

3. Electric System

3.Warning and emergency stop device

(1)PDS185S-6C1(VE PUMP Type)

	Item	Sensor		Actuation	Detecting timing	Time lag
Warning	Discharge air temperature	Thermister	—	Flickering at 239°F (115°C)	Always	1.0 sec
	Engine water temperature	Thermister	—	Flickering at 225°F (107°C)	Always	1.0 sec
	Comp. air filter	Negative pressure SW	a contact	Flickering at differential pressure 0.9psi (6.23kPa)	After starting engine	10 sec
	Eng. air filter	Negative pressure SW	a contact	Flickering at differential pressure 0.9psi (6.23kPa)	After starting engine	10 sec
Emergency	Discharge air temperature	Thermister	—	Lamp goes on at 248°F (120°C)	Always	1.0 sec
	Engine water temperature	Thermister	—	Lamp goes on at 230°F (110°C)	Always	1.0 sec
	Fuel residual level	Thermister	—	Lamp goes on when fuel residual level is less than 3.8gal.(14.5L)	Always	10 sec
	Engine oil pressure	Pressure SW	b contact	Lamp is off when oil pressure is lower than 8.7psi (0.06MPa)	After starting engine and during operation	10 sec 2 sec
	Fuel drain	Float SW	b contact	Lamp goes on when 0.03-0.05gal.(120-170 mL) condensate is accumulated.	Always	10 sec

- Warning : Compressor stops.
- Emergency : Compressor continues to run.

(2)PDS185S-6C1R (IN LINE PUMP Type)

	Item	Sensor		Actuation	Detecting timing	Time lag
Warning	Discharge air temperature	Thermister	—	Flickering at 239°F (115°C)	Always	1.0 sec
	Engine water temperature	Thermister	—	Flickering at 225°F (107°C)	Always	1.0 sec
	Comp. air filter	Negative pressure SW	a contact	Flickering at differential pressure 0.9psi (6.23kPa)	After starting engine	10 sec
	Eng. air filter	Negative pressure SW	a contact	Flickering at differential pressure 0.9psi (6.23kPa)	After starting engine	10 sec
	Fuel residual level	Thermister	—	Lamp goes on when fuel residual level is less than 3.8gal.(14.5L)	Always	10 sec
Emergency	Discharge air temperature	Thermister	—	Lamp goes on at 248°F (120°C)	Always	1.0 sec
	Engine water temperature	Thermister	—	Lamp goes on at 230°F (110°C)	Always	1.0 sec
	Engine oil pressure	Pressure SW	b contact	Lamp is off when oil pressure is lower than 8.7psi (0.06MPa)	After starting engine and during operation	10 sec 2 sec

- Warning : Compressor stops.
- Emergency : Compressor continues to run.

3. Electric System

4. Function of control output relay

Mark	Name	Remark
RY1	Stop signal relay	It switches "OFF" when emergency stop device functions.
RY2	Operation signal relay	After alternator generating signal is inputted, it switches "OFF". (It prevents overrun of starter motor and plunging of pinion gear.)
RY3	Purge/starting unloader relay	It switches "ON" when starter switch is ON. 10 seconds after engine starts (inputting alternator generating signal), it switches "OFF". On purge control unload operation, it switches "ON".

5. Adjustment and inspection

Confirm detection of rise of discharge air temperature/engine coolant temperature by controller and adjustment of purge control setting knob (VR1-VR3) should be performed in accordance with following procedure.

(1) Check and confirm resistance for detecting rise of discharge air temperature (CN2-2) and of coolant temperature (CN2-11).

- 1) Connect resistance to controller as shown right. Or use multi-speed variable resistance (resistance value: 1.0kΩ) for VRc1 and VRc2.

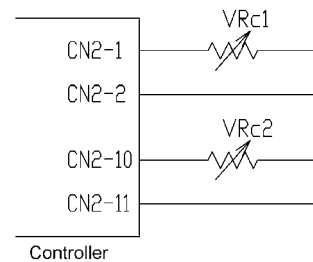

PC08030E

- 2) Gradually lower resistance values of VRc1 and VRc2 and measure them when they reach abnormal values. Then check and confirm that they are within the following ranges.

Item	Set temperature		Resistance
	°C	° F	
Discharge air temperature VRc1	115°C	239 ° F	491 ± 15 Ω
	120°C	248 ° F	432 ± 15 Ω
Engine water temperature VRc2	107°C	225 ° F	608 ± 15 Ω
	110°C	230 ° F	560 ± 15 Ω

(2) Adjustment of purge control setting knob (VR1-VR3)

- 1) Keep pushing indication selector switch (SW1) for 5 seconds.
- 2) Flickering of P Setting purge releasing pressure (VR3) to 0.55[MPa].

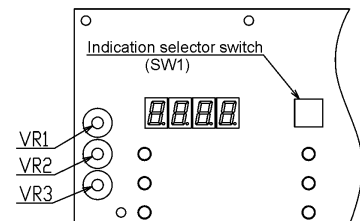

PC08031E

- 3) Flickering of C Setting purge starting intake negative pressure (VR2) to 30[%].
 - 4) Flickering of T Setting purge timer (VR1) to 10 sec.
- Returning to discharge air temperature table.

3. Electric System

6. List of functions

(1) Connector CN1

Pin No.	Line color	Connection	Remark
1	B	Earth	
2	—	NIL	
3	B	Earth	
4	W/B	Stop solenoid [Stop motor relay]	When voltage is applied to CN1-8 terminal by switching "ON" starter switch, voltage is outputted from CN1-4 terminal, and it actuates stop solenoid [stop motor relay]. When starter switch is "OFF" or emergency stop device functions, interior contact (RY1) between CN1-8 and CN1-4 terminal gets "OFF" to cut electrical supply and to cause engine to emergency stop.
5	B/Y	Starter relay No.3 terminal	Turn starter switch to "START" and then it gets electrically connected. (Starting signal inputted from starter relay No.3 terminal is sent from CN1-3 terminal to ground connector.) After starting engine, and when alternator generating signal is inputted to CN2-17 terminal, interior contact (RY2) between CN1-5 and CN1-3 terminal gets "OFF" to prevent overrun of starter motor and plunging of pinion gear.
6	R/Y [R/W]	10A Fuse (Through joint connector No.1 terminal)	Power supply
7	—	NIL	
8	R/Y [R/W]	10A Fuse (Through joint connector No.6 terminal)	Power supply for actuation of stop solenoid valve When starter switch turns "ON", electricity flows between CN1-8 and CN1-4 terminal to actuate stop solenoid valve.
9	L/W	Purge/starting unloader solenoid valve No.1 terminal	When starter switch is switched "ON" and voltage is applied to CN1-6 terminal, interior contact (RY3) between CN1-9 and CN1-3 turns "ON" to get electrically connected and to open the solenoid valve when engine starts. Thus it starts starting unloader operation and makes engine smoothly start at light load. When CN2-17 terminal receives alternator generating signal input after engine starts, controller timer starts to disengage the contact "OFF" in 10 seconds. Then the electrical connection is cut to close the valve. This starting unloader operation of this valve is disengaged and compressor starts normal operation. ● When AUTO IDLE (PURGE CONTROL) SWITCH is ON When pushing AUTO IDLE switch during operation, it will be switched to purge control operation. When compressor is transferred to unloaded operation by reduction of air consumption and intake negative pressure at secondary aide increases. During operation of purge control, this sensor detects this negative pressure and outputs it to controller for operation control. When the intake valve to controller passes under the set pressure (standard value: negative pressure 30%) for a certain time, the interior contact (RY3) turns "ON". Thus purge/starting unloader solenoid valve is electrically connected to open the valve to reduce the pressure in receiver tank and switched to purge operation.

The data in [] show those of electric apparatus used for PDS185S-6C1R. (IN LINE PUMP type).

3. Electric System

(2)Connector CN2

Pin No.	Line color	Connection	Remark
1	G/B	Discharge air temp. sensor No.1 terminal	Detection of discharge air temperature. It ignites controller surface warning: emergency stop lamp at higher temperature than set one. Also when it is higher than the emergency stop actuating set temperature, interior contact (RY1) between CN1-4 and CN1-8 terminals will be turned "OFF" to make engine emergency stop. ●Warning·Emergency stop set temperature Warning temperature:239°F(115°C) Emergency stop temperature:248°F(120°C)
2	G/W	Discharge air temp. sensor No.2 terminal	
3	B	Earth	
4	G	Service pressure sensor No.2 terminal	Detection of service pressure.
5	W	AUTO IDLE (purge control) switch No.1 terminal	When auto idle (purge control) is switched "ON" to be electrically connected, it will be switched to purge control mode.
6	G/L	Engine air filter	Detection of engine air filter clogging.
7	G/R	Compressor air filter	Detection of compressor air filter clogging.
※1 8	G	Engine oil pressure switch	It is electrically connected during normal operation. When engine oil pressure drops, engine oil pressure switch turns "OFF" to cut electrical connection. When electrical connection is cut, interior contact (RY1) between CN1-4 and CN1-8 terminal turns "OFF" to cause emergency stop to engine. ●Set pressure of emergency stop oil pressure below 8.7psi (0.06MPa)
9	—	NIL	
10	G/B	Coolant temp. sensor No.1 terminal	Detection of engine coolant temperature. When temperature exceeds the set temperature, it ignites controller surface warning /emergency stop lamp. Further, when the set temperature of emergency stop becomes higher, the interior contact (RY1) between CN1-4 and CN1-8 terminals turns "OFF" to cause engine to emergency stop. ●Warning·Emergency stop set temperature Warning temperature:225°F(107°C) Emergency stop temperature:230°F(110°C)
11	Y/B	Coolant temp. sensor No.2 terminal	
12	R	Service pressure sensor No.1 terminal	Power supply for pressure sensor.
		Intake negative pressure sensor No.1 terminal	
13	Y	Intake negative pressure sensor No.2 terminal	Detection of intake negative pressure.
14	L/W	Glow controller No.4 terminal	Input of pre-heater ignition signal.

3. Electric System

Pin No.	Line color	Connection	Remark
※2 15	G/Y	Fuel filter No.1 terminal	No electrical connection found. When condensate in fuel filter exceeds set volume, floating switch inside the filter turns "ON" to be electrically connected with this terminal electrically connected, the contact (RY1) between CN1-4 and CN1-8 terminals turns "OFF" to make engine emergency stop. ●Emergency stop set volume:0.03-0.05gal.(120-170mL)
16	Y/L	Sending unit No.2 terminal	No electrical connection found. When fuel residual volume decreases, fuel level switch turns "ON" and gets electrically connected, the contact (RY1) between CN1-4 and CN1-8 terminals turns "OFF" to make engine emergency stop. ●Residual fuel volume for emergency stop: less than 3.8gal.(14.5L)
17	Y/G	Alternator P terminal	Generating signal inputted for disengaging starter motor. When frequency of P terminal exceeds $190 \pm 10\text{Hz}$ starter relay contacts is switched to disengage starter motor.

※1 : Abnormal oil pressure detection circuit of controller starts to function in 10 seconds after it detects alternator generating signal with CN2-17 terminal.

※2 : Emergency stop circuit detecting fuel filter condensate accumulation is installed on PDS185S-6C1 (VE pump type) only.

3. Electric System

3.1.3 Alternator

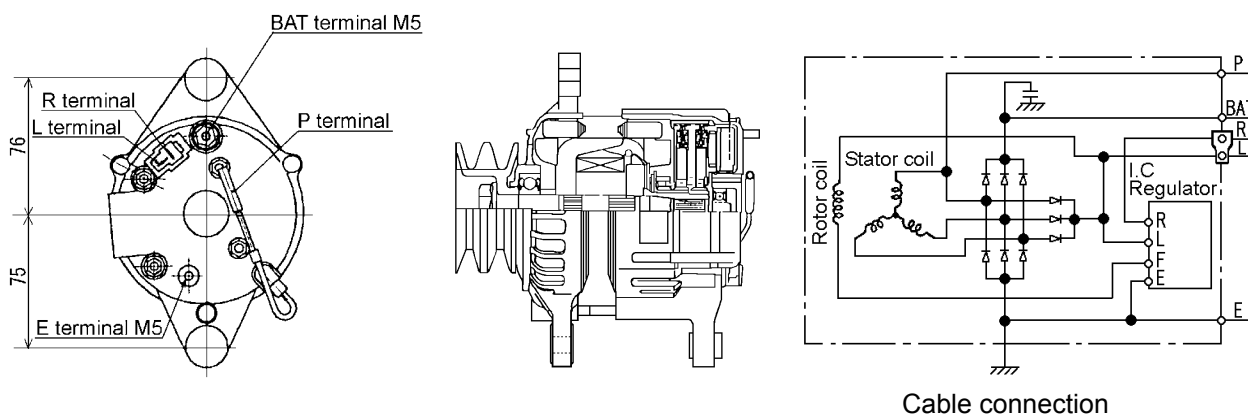

(1) List of functions

Pin No.	Line color	Connection	Remark
BAT	R	Starter motor B terminal	Power for charging voltage.
R	R/W	10A Fuse (Through joint connector)	Detect output voltage from alternator and adjust the current flowing to rotor coil.
L	W	Hour meter	Signal output for hour meter.
※ P	Y/G	Controller CN2-17 terminal	For separating starter motor. When frequency of P terminal exceeds $190 \pm 10\text{Hz}$, starter relay contact is switched through controller, and it disengages starter motor.
E	B	Earth	

※:For diagnosing P terminal, check the generating voltage between P-E terminal and it is normal if the voltage detected is about DC7.2V.

(2) Judgement of alternator functions

Checking method by measuring battery terminal at full load operation	Normal Value
Measure the battery terminal voltage at full load operation.	$14.4 \pm 0.3\text{V}$

3. Electric System

(3) Diagnosing when battery charging warning lamp lights

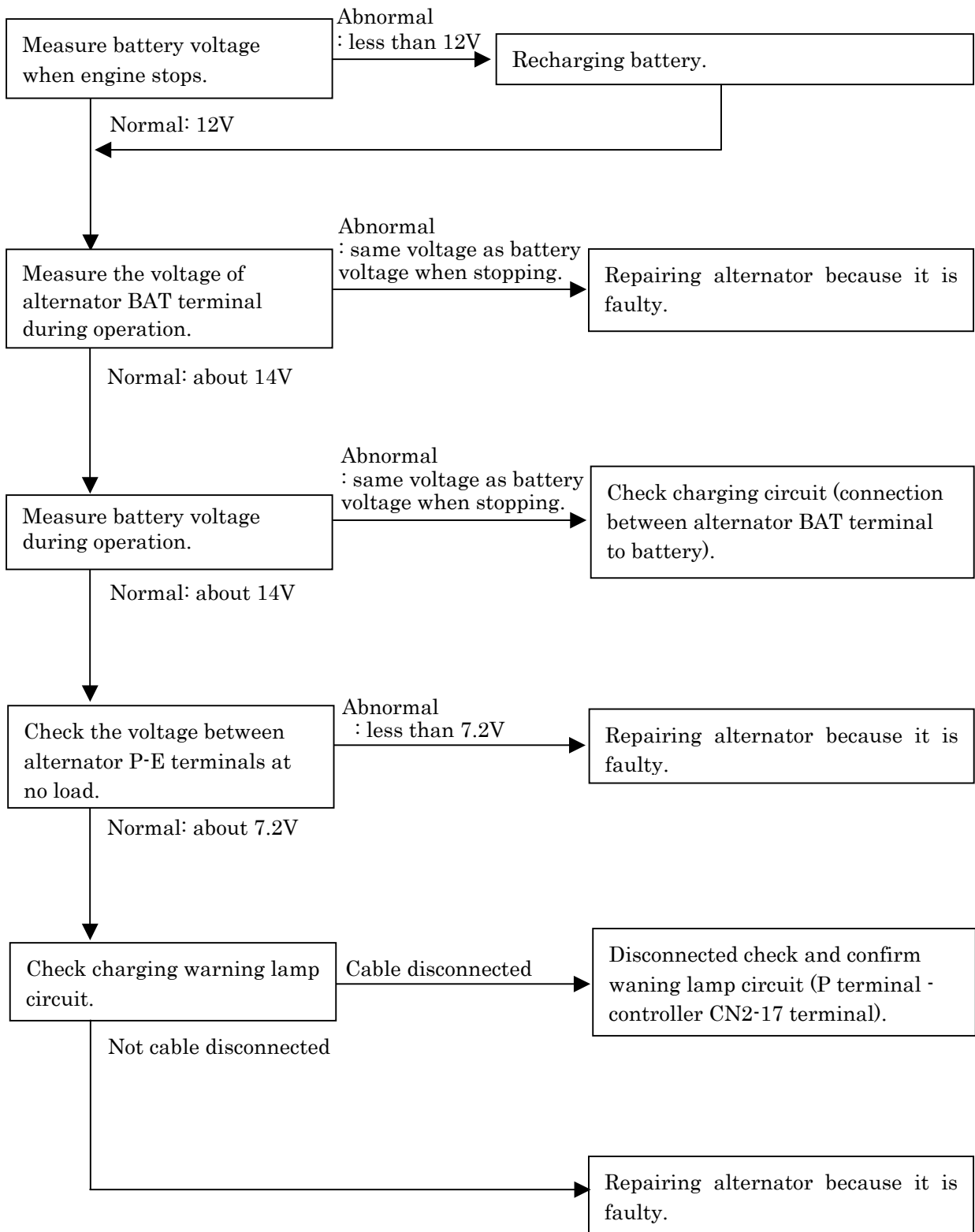

3. Electric System

3.1.4 Glow controller (QGS II)

Part number:44327 04100

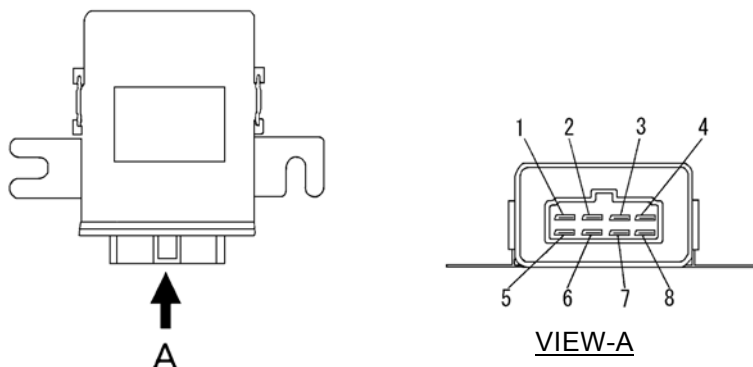

(1) Coolant temperature · glow instantaneous characteristic (at the time of key-OFF-ON)

Water temp.°F (°C)	Lamp lights time t1 (sec)
5 (-15)	5.0
32 (0)	3.5
104 (40)	1.8

Voltage of No.6 terminal (V)	Glow time t2 (sec)
9.5	14.0
11	6.0
13	2.4

(2)List of functions

Pin No.	Line color	Connection	Remark
1	B/W	Starter switch C terminal	Detection of starter signal
2	G/W	Water temperature sensor	Detection of water temperature
3	B	Earth	
4	L/W	Controller CN2-14 terminal	Ignition of pre-heating pre-glow (pre-glow) lamp.
5	Y/R	Glow relay No.3 terminal	Power supply for glow relay. When voltage is applied to No.7 terminal, it pre-heats for a certain time in accordance with the voltage applied to the water temperature and glow plug. When water temperature is lower than 122°F(50°C), it repeats after glow for 15 seconds.
6	L	Glow plug	Detection of glow plug voltage.
7	W/R	10A Fuse	Power supply
8	—	NIL	

(3) Chart of function

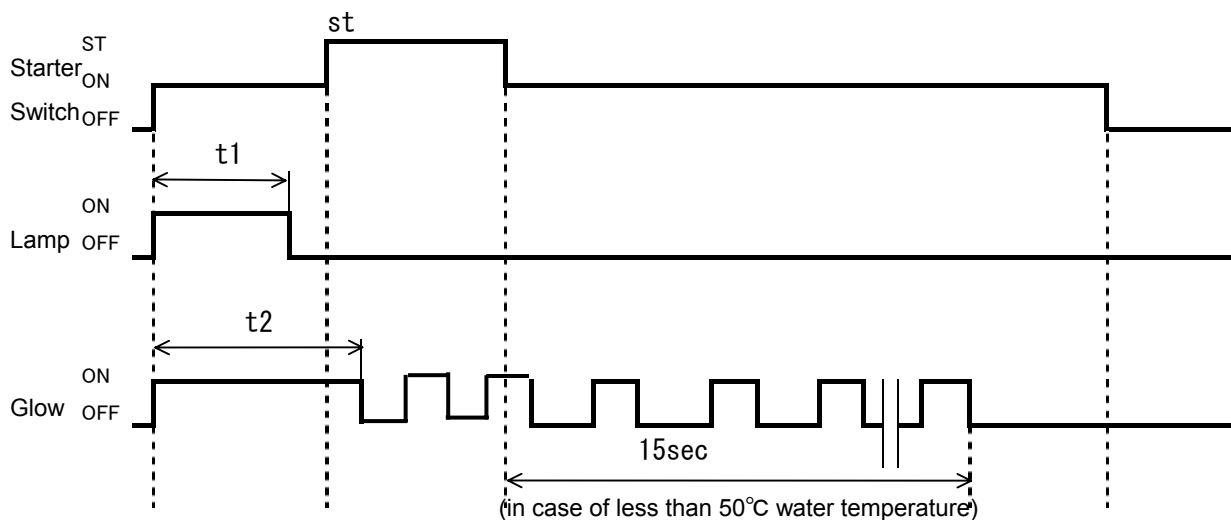

3. Electric System

3.1.5 Solenoid valve

Part number:46811 24100

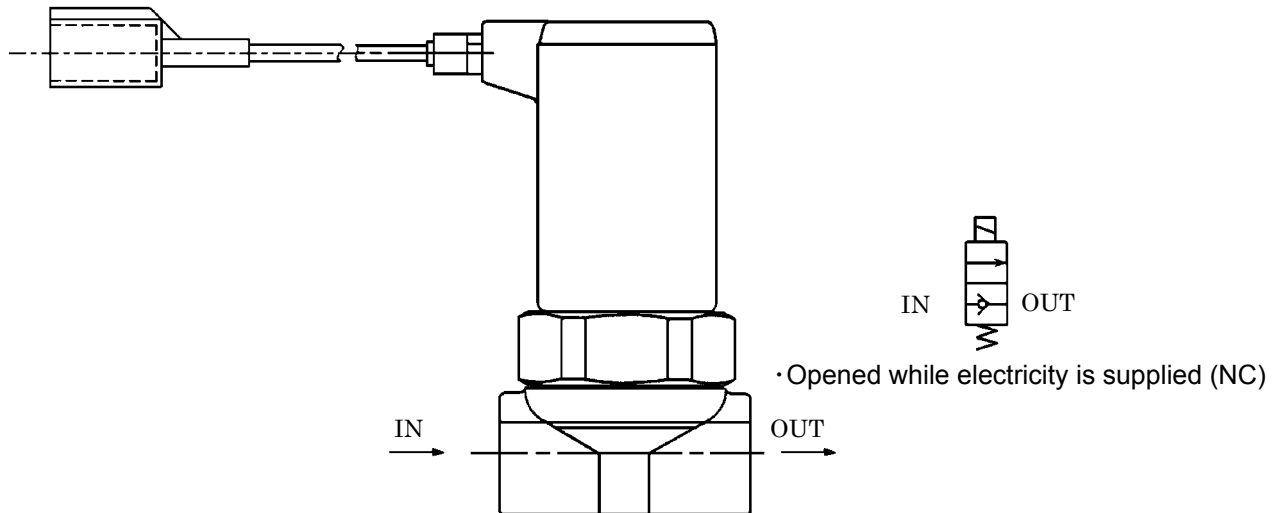

PC08032

Purge/starting unloader solenoid valve (NC)

● Function

When voltage is applied to CN1-6 terminal (power supply) of controller with the starter switch “ON”, interior contact (RY3) controller CN1-9 and CN1-3 terminal turns “ON”, purge/starting unloader solenoid valve gets electrically connected to be opened. Thus after engine starts, compressor can perform starting unloader operation, starting engine smoothly at light load. When controller CN2-17 terminal receives alternator generating signal, controller timer begins to function and in 10 seconds the internal contact (RY3) turns “OFF” and cut electrical connection to close the valve. Compressor will be released from starting unloader operation mode and returns to normal operation.

● AUTO IDLE SWITCH “ON”

Pressing auto idle switch during operation, it will be switched to purge control operation mode. When compressor is transferred to unloaded operation according to reduction of air consumption, the intake negative pressure at secondary side increases. During purge control operation, the sensor detects intake negative pressure and it outputs to controller. When a certain time has passed with the value inputted to controller kept less than the set value (standard set value: 30% load factor), the internal contact (RY3) will be connected “ON”. Accordingly, the solenoid valve for purge/starting unloader is electrically connected to open the valve to reduce the receiver tank pressure and switched to purge mode operation.

3. Electric System

3.1.6 Discharge air temperature sensor, Coolant temperature sensor

Part number:44364 06500

Characteristic of temperature resistance

Water temp. °F (°C)	Resistance (kΩ)	Permissibl e Value (%)
176 (80)	1300	±7
203 (95)	840	±6
230 (110)	560	±5
239 (115)	490	±6

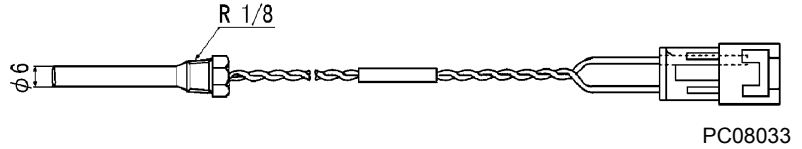

«Note» Take care not to tighten excessively.
Less than 1.96N·m(20kgf·cm)

3.1.7 Engine oil pressure switch (For emergency stops)

Part number:44328 19100

Specification

Setting pressure	8.7psi (0.06MPa)
Contact type	A contact switch (Contact "ON" in excess of set pressure)
Time lag	<ul style="list-style-type: none"> • 10 seconds after engine starts. • 2 seconds during operation

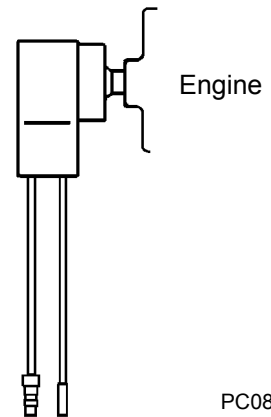

3.1.8 Intake negative pressure sensor, service pressure sensor

Part number:44328 20600

Pressure and output voltage

Electric wire	Signal
①VCC	Power supply (5V)
②VOUT	Output
	Pressure 0psi (0MPa) DC0.5V
	Pressure 14psi (0.1MPa) DC0.9V
	Pressure 85psi (0.6MPa) DC2.9V
	Pressure 100psi (0.69MPa) DC3.3V
Pressure 142psi (0.98MPa) DC4.5V	
③GND	Earth

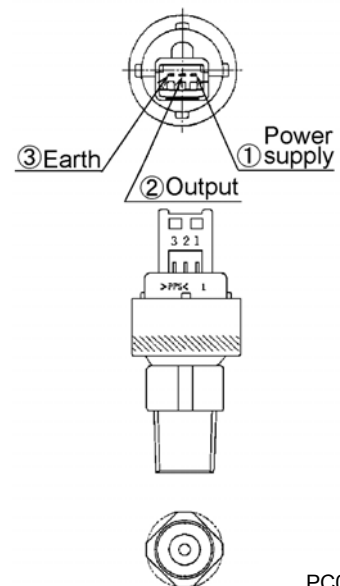

To check output voltage of pressure sensor for diagnosis of trouble, it is necessary to measure the voltage between ②-③terminals.

3. Electric System

3.1.9 Fuel meter

Part number:36158 00500

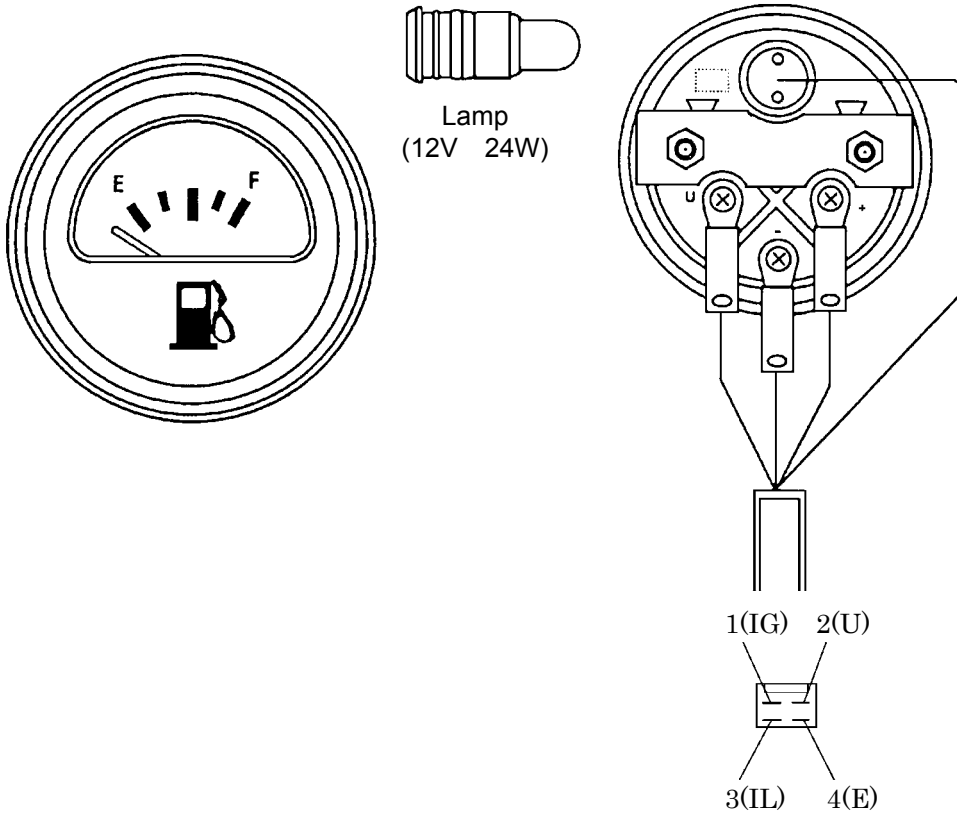

PC08036

(1) Position of meter pointer

Pointer position	Resistance (Ω)	Remaining fuel gal.(L)
E	95	5.3 (20)
1/2	32.5	14.5 (55)
F	7	21.1 (80)

(2) List of functions

Pin No.	Line color	Connection	Remark
1(IG)	R/Y	10A Fuse	Power source for fuel gauge
2(U)	Y/B	Sending unit	Detector for remaining fuel
3(IL)	R/Y	10A Fuse	Power source for lighting
4(E)	B	Earth	

3. Electric System

3.1.10 Sending unit (With fuel level switch)

Part number:36159 04100

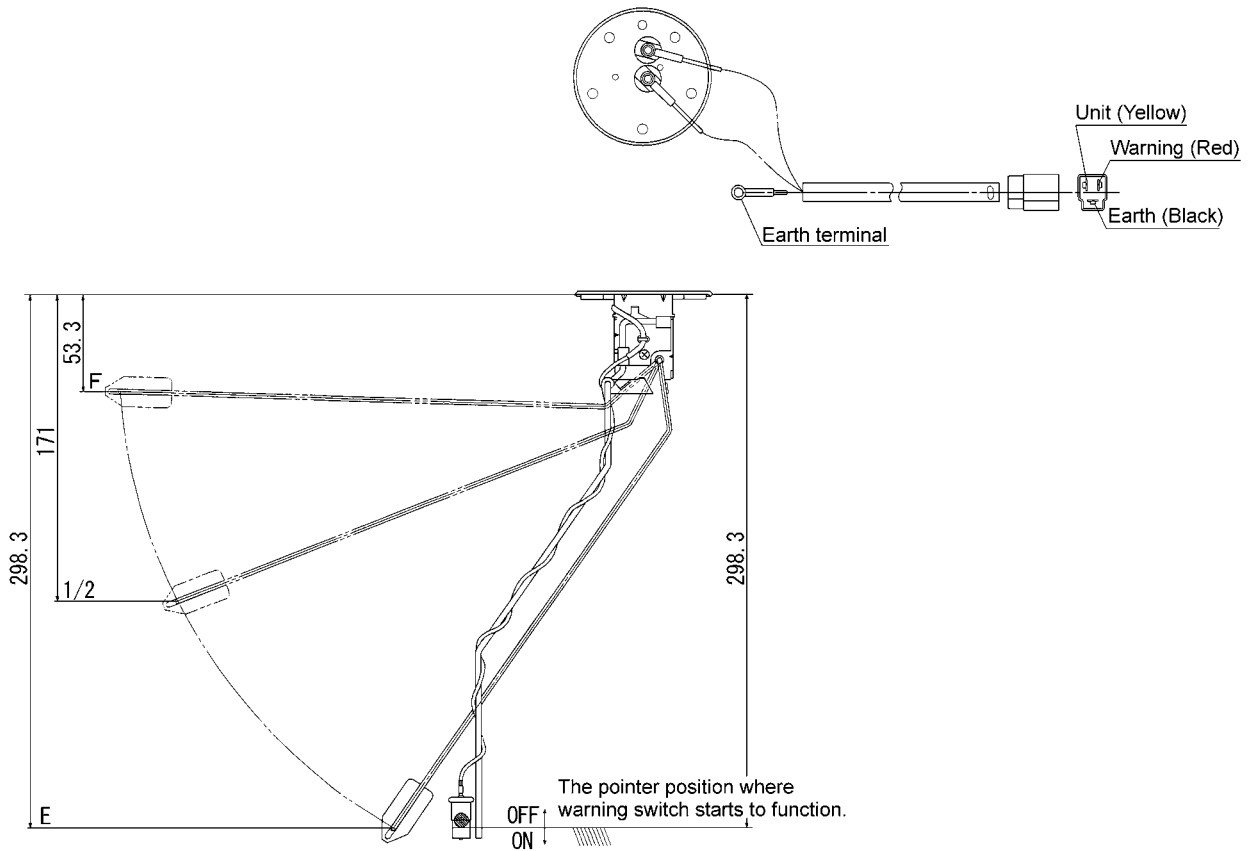

PC08037E

Pointer position	Resistance (Ω)	Remaining fuel gal.(L)
E	110	5.3 (20)
1/2	32.5	14.5 (55)
F	3	21.1 (80)

3. Electric System

3.1.11 Fuel filter (PDS185S-6C1 VE PUMP Type only)

Part number:43540 07400

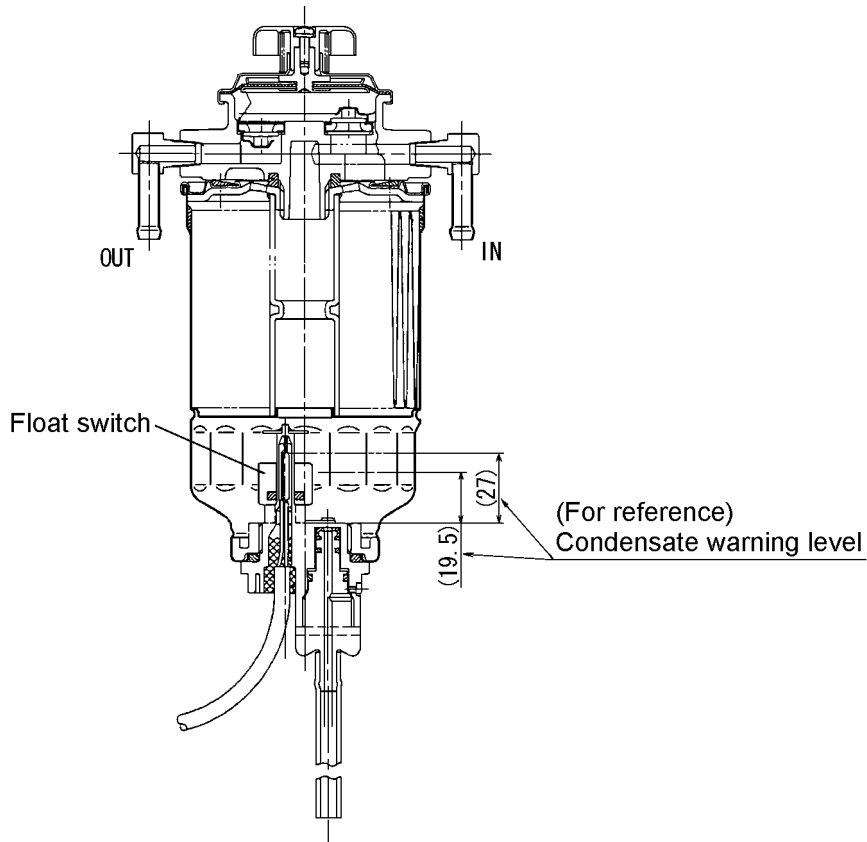

PC08038E

● Functions

During normal operation, it is not electrically supplied.

When water level inside fuel filter rises and becomes more than 0.03-0.05gal.(120-170mL), the floating switch inside filter gets “ON” for electrical connection to controller CN2-15 terminal. After electrical connection to stop solenoid continues 10 seconds and it is cut, it causes engine emergency stop. (Time lag: 10 seconds)

3.1.12 Fuel air-bleeding electromagnetic pump (PDS185S-6C1R IN LINE PUMP Type only)

Part number:43650 01900

Specification

Rated voltage	12V
Operating current	1.5A(MAX)
Delivery capacity	More than 0.4L/min

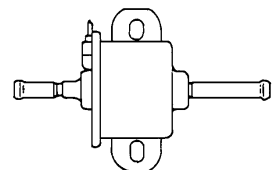
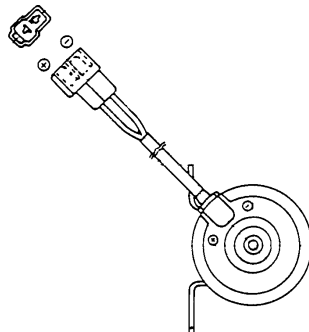

3. Electric System

3.1.13 Stop solenoid (PDS185S-6C1 VE PUMP Type only)

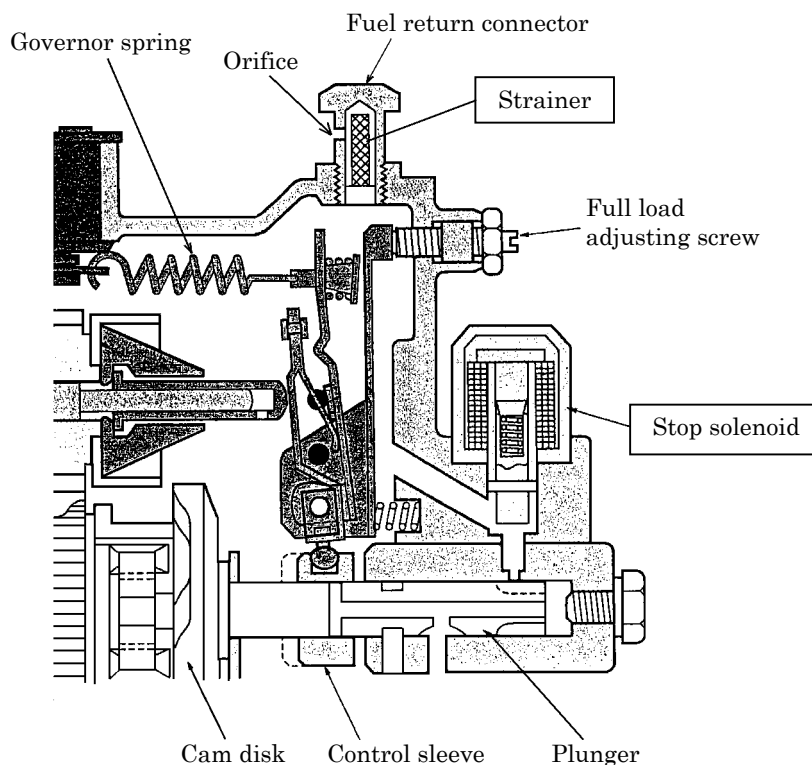

PC08039

(1) Specification

Rated voltage		DC12V
Power consumption		16W
Pull·Holding	Current	1.33A
	Resistance	9.02 Ω

1. Replacement of stop solenoid

Stop solenoid may intervene with dumper proof (full load adjusting portion) when it is being replaced. Therefore, it is impossible to remove stop solenoid only. When it is necessary to remove it, it is better to contact Bosch Service Department or injection pump assembly.

2. Position of strainer installment inside VE pump

Injection pump is equipped with a strainer in connector of fuel return pipe. This strainer is provided to prevent clogging of the orifice (about 0.5mm) provided to keep the fuel pressure in the pump constant (Installation: one position). This function is not different from that of inline pump gauze filter.

3. Electric System

3.1.14 Stop motor (PDS185S-6C1R IN LINE PUMP Type only)

Part number:44358 01200

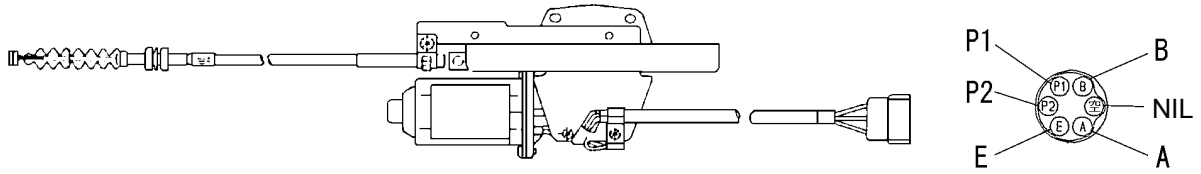

PC08040

List of functions

Pin No.	Line color	Connection
P1	L/B	Stop motor relay No.6 terminal (NC)
P2	L/Y	Stop motor relay No.5 terminal (NO)
E	B	Earth
A	R/B	Stop motor relay No.3 terminal (COM)
	—	NIL
B	R	20A Fuse (Power supply)

3. Electric System

[Function of stop motor]

1. Before engine starts

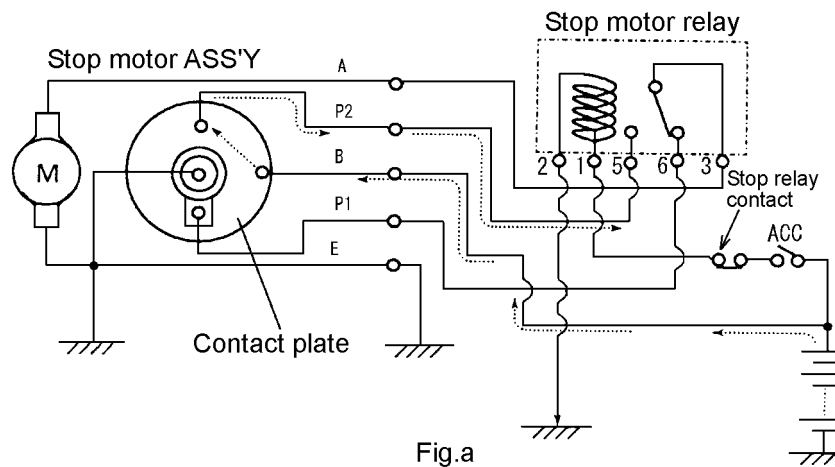

Fig.a

PC08041E-1

- ① As the ACC contact is open before starting engine, the exciting current is not provided, but internal contact is as shown in fig a.
- ② When the contact plate inside the stop motor assembly is positioned as shown in fig a, there is a conduction between B terminal and P2 terminal. Accordingly, the voltage of the battery is applied to No.5 terminal of stop motor relay.

2. Engine starts

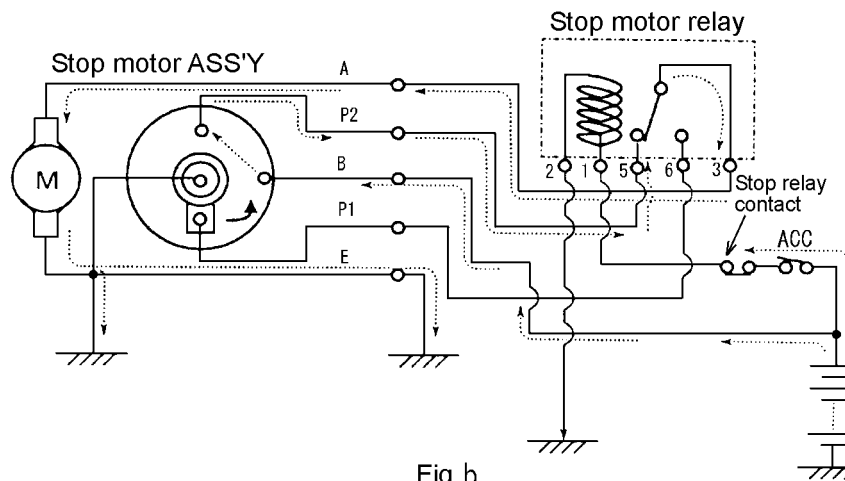

Fig.b

PC08042E-1

- ① When closing the ACC contact by handling the starter switch ("Operation" position), the circuit of controller inside contact between CN1-8 terminal and CN1-4 terminal → stop motor relay No.1 terminal → exciting coil → stop motor relay No.2 terminal → grounding is formed and the stop motor relay is excited. Accordingly, stop motor relay contact functions.
- ② As the voltage of battery is already applied to the stop motor relay CN3-5, the circuit of stop motor relay No.5 terminal → stop motor relay No.3 terminal → stop motor A terminal → motor → grounding is formed and the motor starts.

3. Electric System

3. Rotation of contact plate

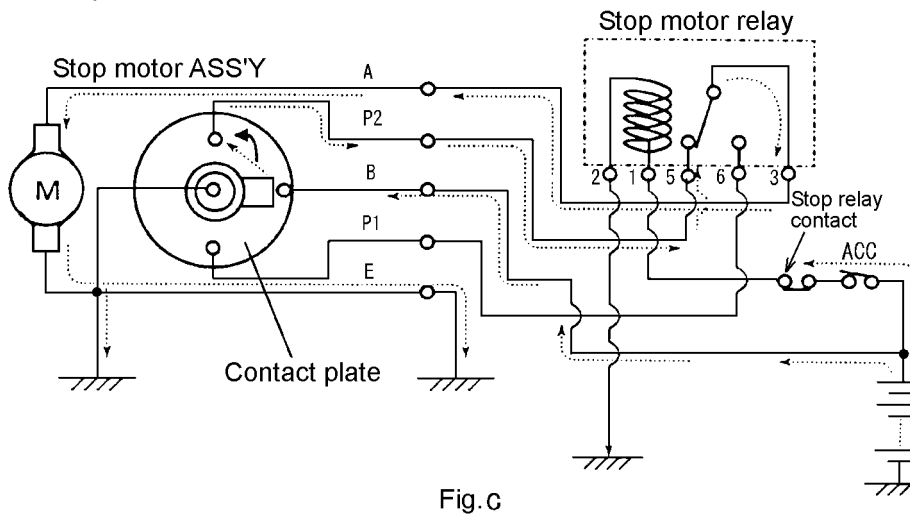

Fig. c

PC08043E-1

- ① When motor begins to rotate, the worm fitted to the motor shaft rotates and at the same time worm wheel rotates.
- ② The worm wheel and contact plate are interconnected and so it continues to rotate as shown in Fig C.

4. Stop of contact plate rotation

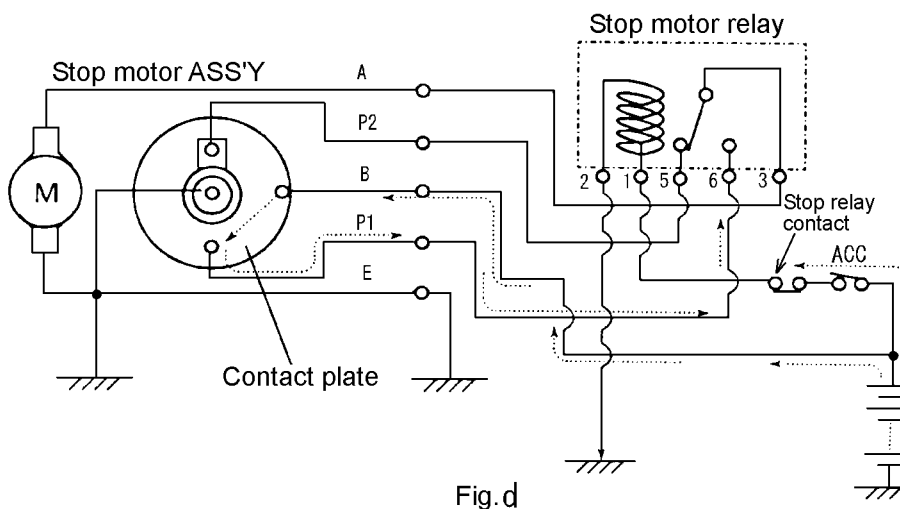

Fig. d

PC08044E-1

- ① When the contact plate turns 180° degree from the state at which it stays, the electrical conduction disappears between B and P2 terminal as shown in Fig.d, P2 terminal is connected to the grounding side. Further, it follows that the armature of the motor gets short-circuited and so it is electrically braked so that the contact plate stops surely at the constant position
- ② At the same time worm rotation is reduced by worm wheel, and further the rotation will be changed for reciprocal movement via the lever. The stroke extends the wire to move the fuel lever fitted at the injection pump to open the fuel circuit.
- ③ When the contact plate stays at the position shown in fig d, the conduction appears between B and P1 terminal and so the voltage of battery is applied to stop motor relay No.6 terminal.

3. Electric System

5. Engine stops (normal stop)

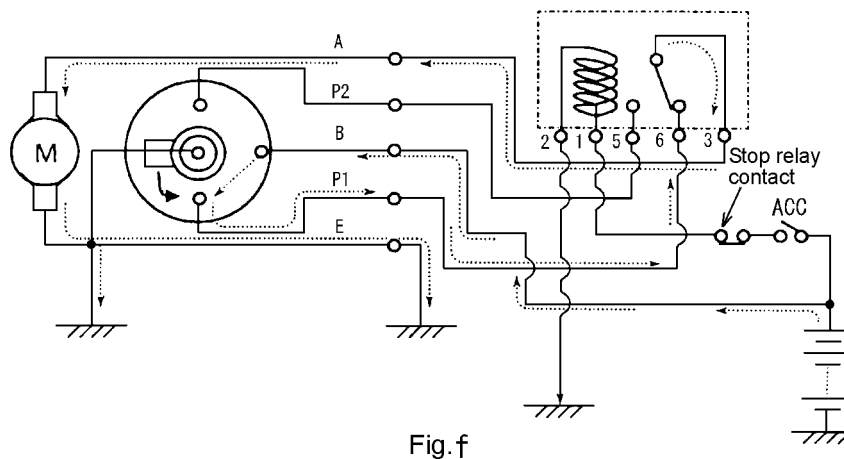
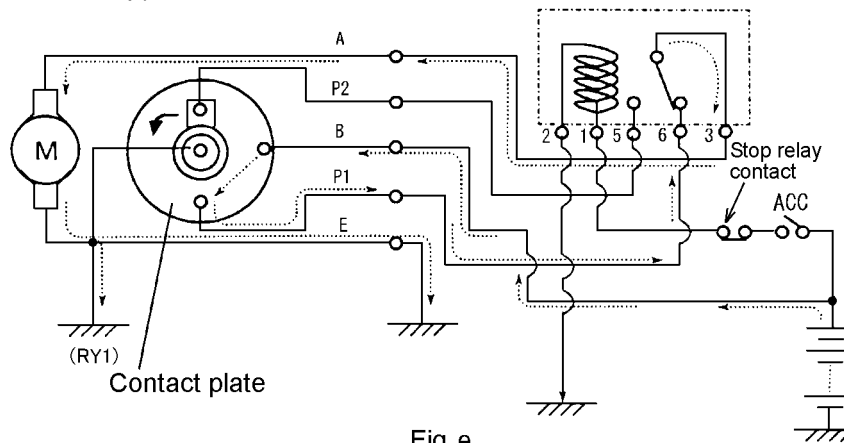

PC08045E-1

- ① To stop engine, handle starter switch to open ACC contact (“Stop” position) so that excitation circuit of stop motor relay may be released to move the contact point as shown in Fig e.
- ② As the voltage of battery is already applied to stop motor relay No.6 terminal, the circuit of stop motor relay No.3 terminal → stop motor A terminal → motor → grounding is formed and so the motor turns and at the same time the contact plate also turns as shown in the fig f.
- ③ The contact plate continues to turns from 180° position shown Fig e to the 360° position in Fig a via Fig f position. At the same time when the contact plate rotates the wire is pulled to close fuel line circuit by the fuel line connected to injection pump to close the fuel circuit to stop engine.
- ④ Motor and contact plate stop to rotate at specified position in Fig a, and return to the position in the clause “ 1. Before engine starts ”.

6. Emergency stop

When any abnormalities are found in engine oil pressure, water temperature and discharge air temperature, controller emergency stop circuit functions, interior contact (RY1) starts to function to open the switch and to release stop motor relay exciting circuit. The process till “5.engine stops” is same after engine stop (normal stop).

4. Troubleshooting

4.1 Repairing Procedures

When performing failure diagnosis, pay special attention to the followings, observing general cautions.

4.1.1 Safety caution

- (1) Removing such cap and/or plug for receiver tank, fuel tanks and pipes where pressure is loaded, stop the machine and relieve all the interior pressure. Install measuring instruments connected firmly.
- (2) When doing the job with co-worker(s) together, make sure to give signal to the other person(s) and do not allow other persons to come near to the job site.
- (3) Take care not to touch hot portions and not to be involved in turning portions.

4.1.2 Caution during failure diagnosis

- (1) Do not make haste to disassemble the unit

If the unit is disassembled urgently.

- ① You may disassemble the other portions which are not related with the trouble.
- ② The cause of trouble may be missing.

The unnecessary reparations require more spare parts and man-hours, and reparation costs will increase more. What is worse, you will lose reliance or trust from clients, operators and users.

Therefore, it is absolutely necessary to investigate the trouble more carefully in advance and to follow the required procedures for failure diagnosis.

- (2) Ask the clients about the trouble in details

In order to prevent misunderstanding and incorrect judgment about the trouble, it is necessary to ask users or operators about the following questions.

- ① Is there any other disorder than the trouble he has informed?
- ② Anything abnormal occurred before this trouble?
- ③ Did this trouble happen unexpectedly? Or the unit had been operated in bad conditions before?
- ④ When and how did this trouble occur?
- ⑤ Had he repaired the unit before this trouble occurred?
- ⑥ Did he not experience similar trouble before?

- (3) Inspection items before starting diagnosis

Sometimes such trouble may be caused owing to routine mishandling of the unit. Before starting failure diagnosis, check the following items.

- ① The engine runs short of engine oil or its oil is not dirty?
- ② Check each wire connection for any disconnection.
- ③ Check the other portions for any damage.

- (4) Confirmation of trouble

Discuss with user(s) and/or operator(s) sufficiently about the trouble. As a result, judge whether their judgment is based on the numerical comparison or sentimental basis. Make him (them) understand well the reparation or correction you have finished.

Then check and confirm by yourself the cause of the trouble.

Note) Never proceed any investigation or measurement which may cause further greater damage.

4. Troubleshooting

(5) Procedures of diagnosis

When you become well experienced, you can find out the cause easily during the process of confirmation (4). But easy understanding could cause unexpected failure. So check and judge it according to the following procedures.

- ① Check the easiest thing or portion first.
- ② Investigate the most possible cause.
- ③ Check the other things connected to the trouble.
- ④ Check for the possibility of any other troubles.
- ⑤ Start proper and careful investigation on this trouble.

(6) Prevention of repeated occurrence of similar trouble

Even if you have repaired the trouble, unless you get rid of the fundamental cause of the trouble, it will repeatedly occur. Therefore, perform full investigation of the trouble, and it is absolutely necessary to remove the basis of the trouble.

4.1.3 How to use the failure diagnosis

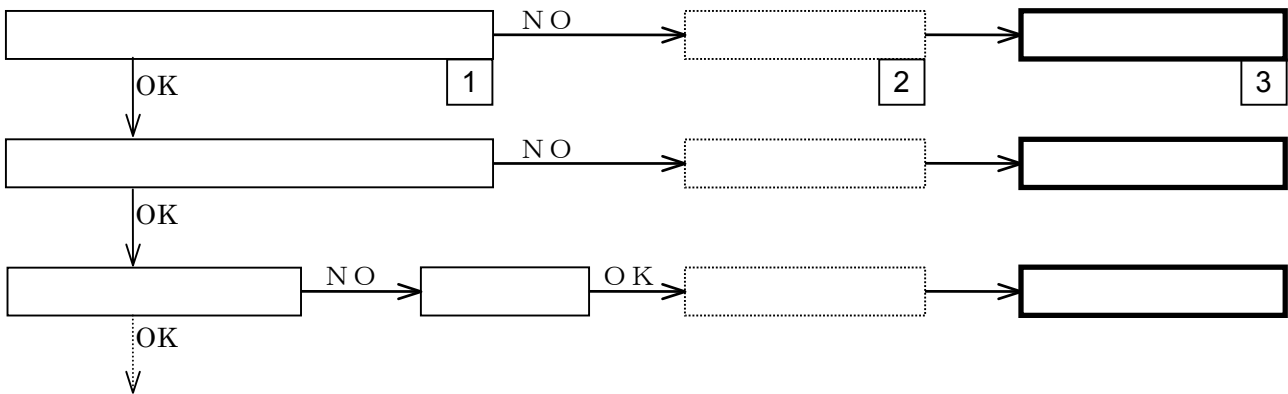

① In the troubleshooting column something abnormal is mentioned in lined parenthesis.

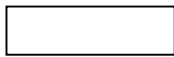

② In the troubleshooting column the cause of the said trouble is mentioned in dotted parenthesis.



③ In the troubleshooting column the countermeasures or treatment are mentioned in the double lined parenthesis.



④ 1 under each column means the index of explanation.

For details, see 4.5 “Explanation of trouble diagnosis”

4. Troubleshooting

4.2 Failures of compressor and engine

4.2.1 At start-up, starter rotates slowly

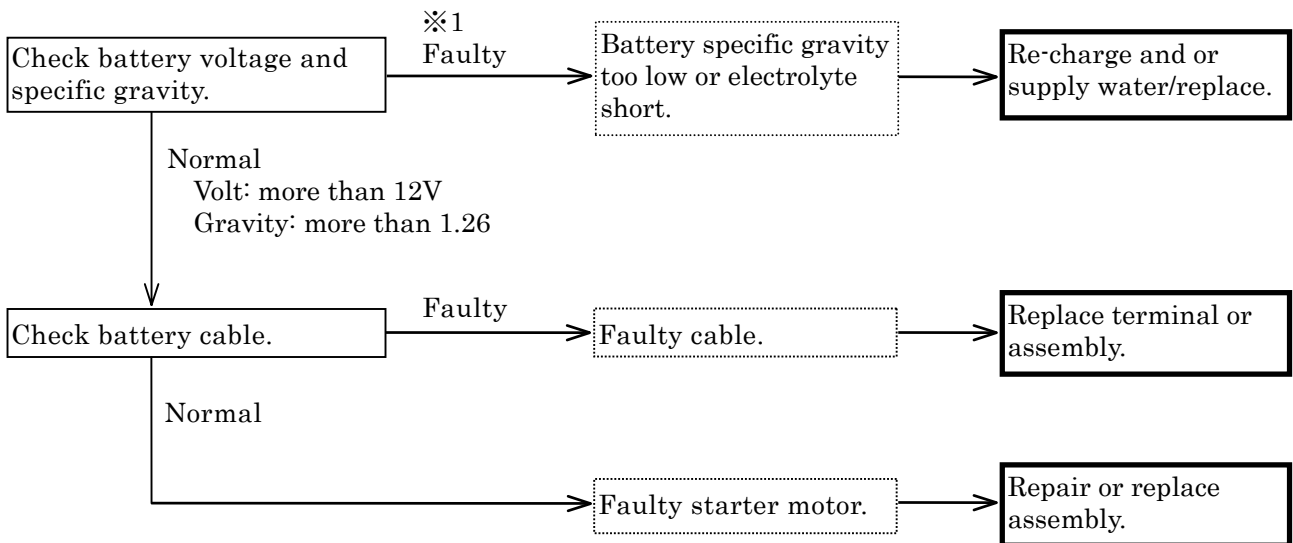

※1 : When starter switch is placed at the “START” position, the battery is not normal if B terminal voltage decreases by 10V.

4.2.2 Receiver tank gauge pressure will not rise up to rated pressure during unloaded operation

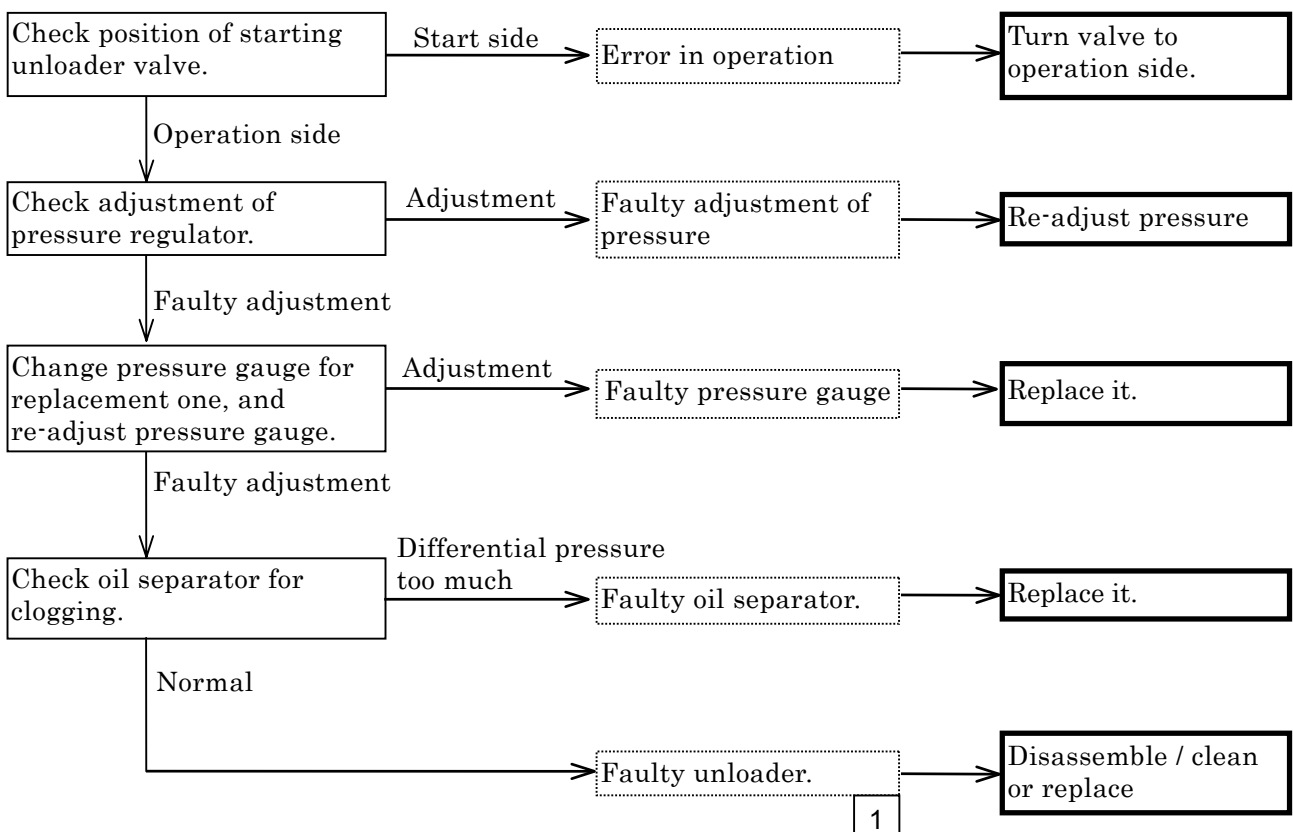

4. Troubleshooting

4.2.3 Engine revolutions will drop before pressure rises up to rated one

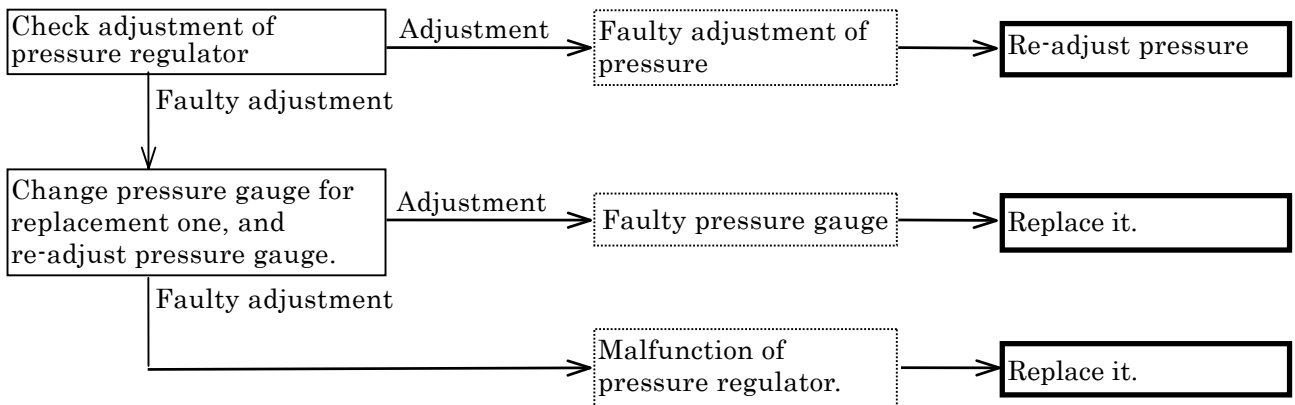

4. Troubleshooting

4.2.4 Engine will not turn to meet rated revolutions

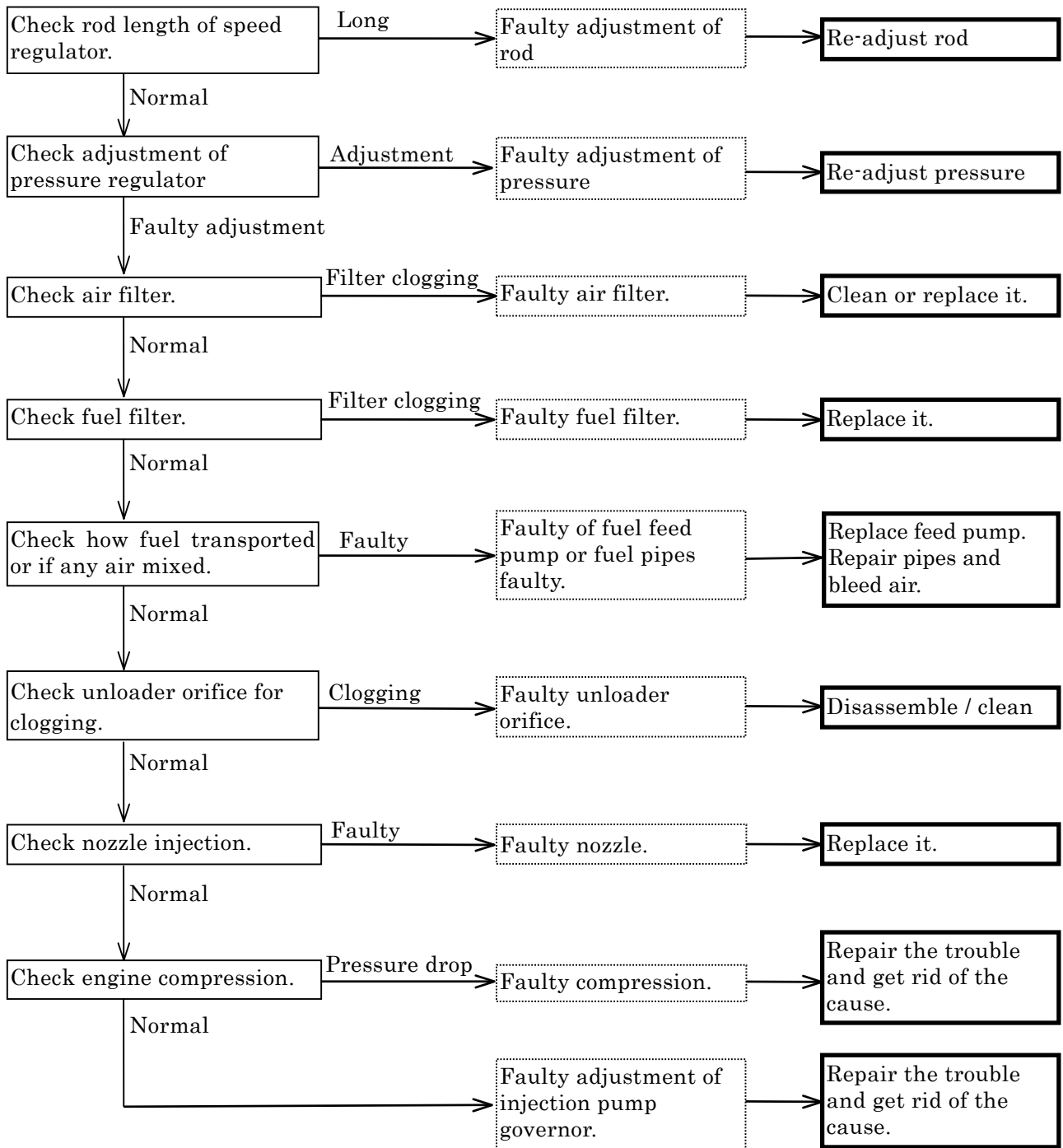

4. Troubleshooting

4.2.5 Engine RPM will not drop to lowest RPM during unloaded operation

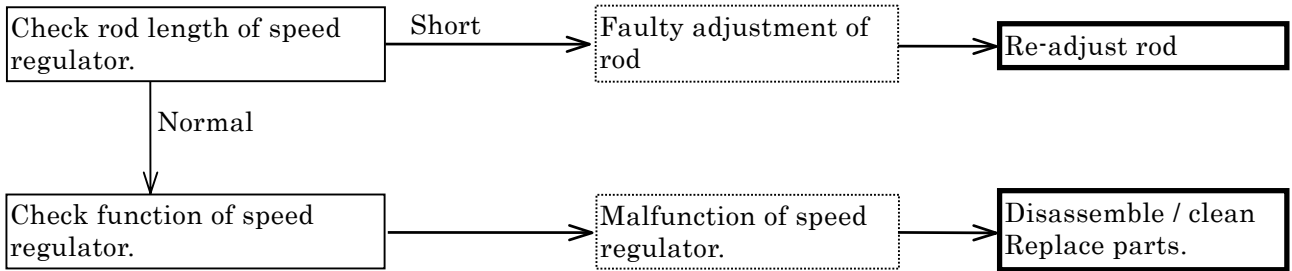

4.2.6 Safety valve bursts out during unloaded operation

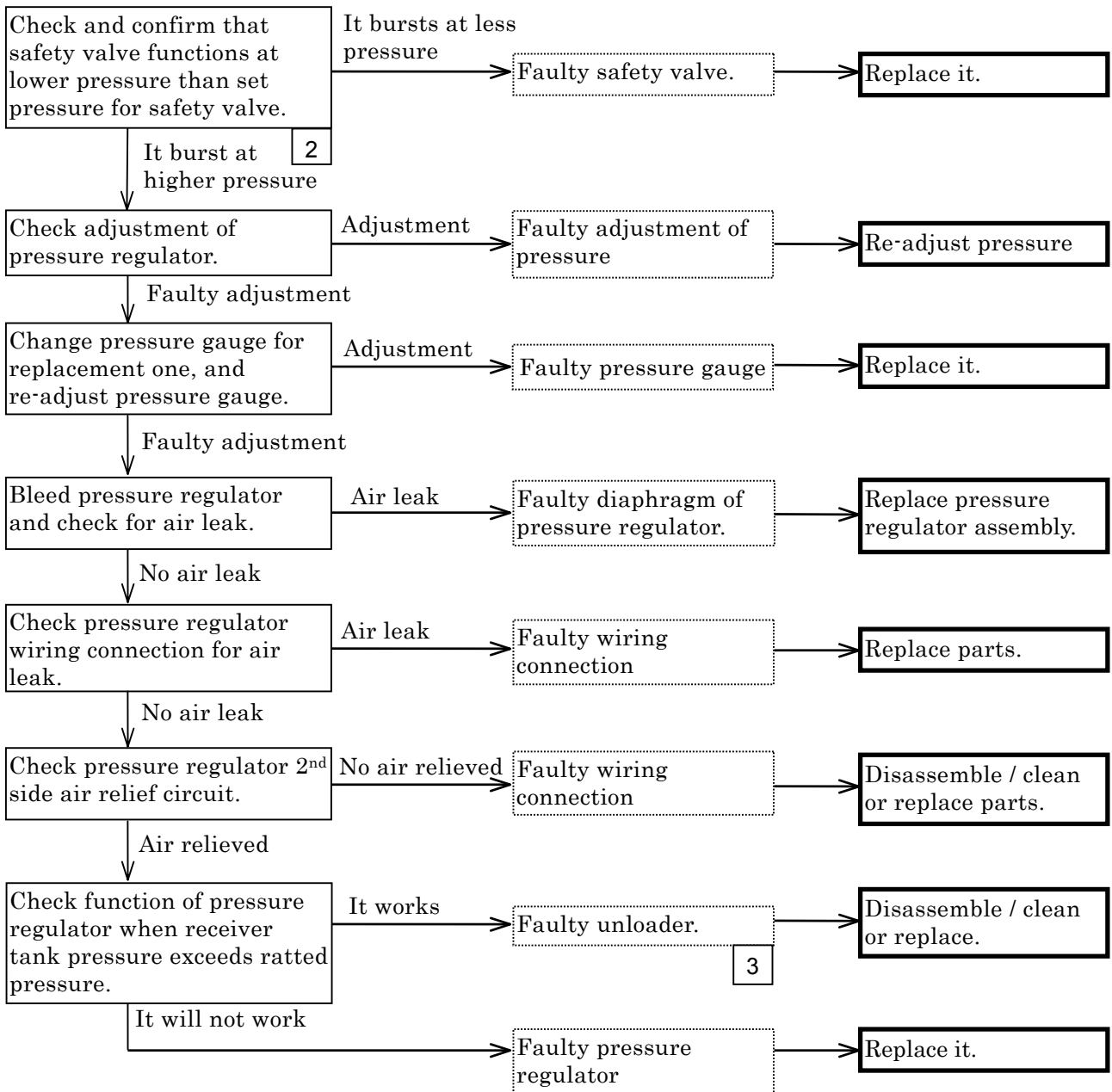

4. Troubleshooting

4.2.7 Oil mixed found in delivery air

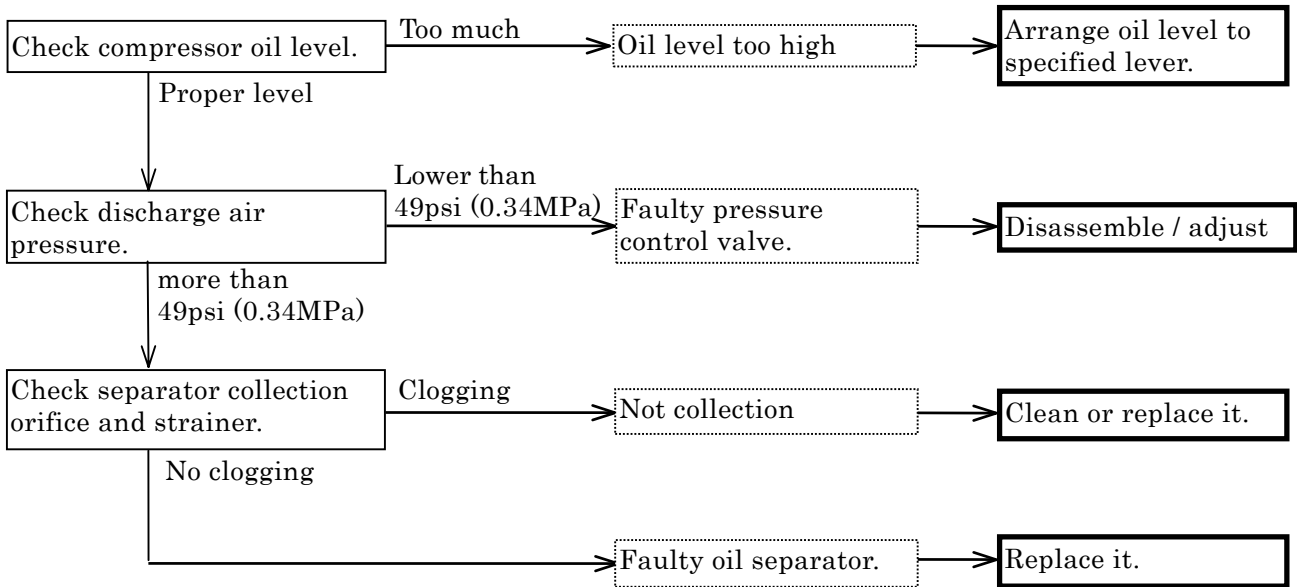

4. Troubleshooting

4.2.8 Discharge air is insufficient

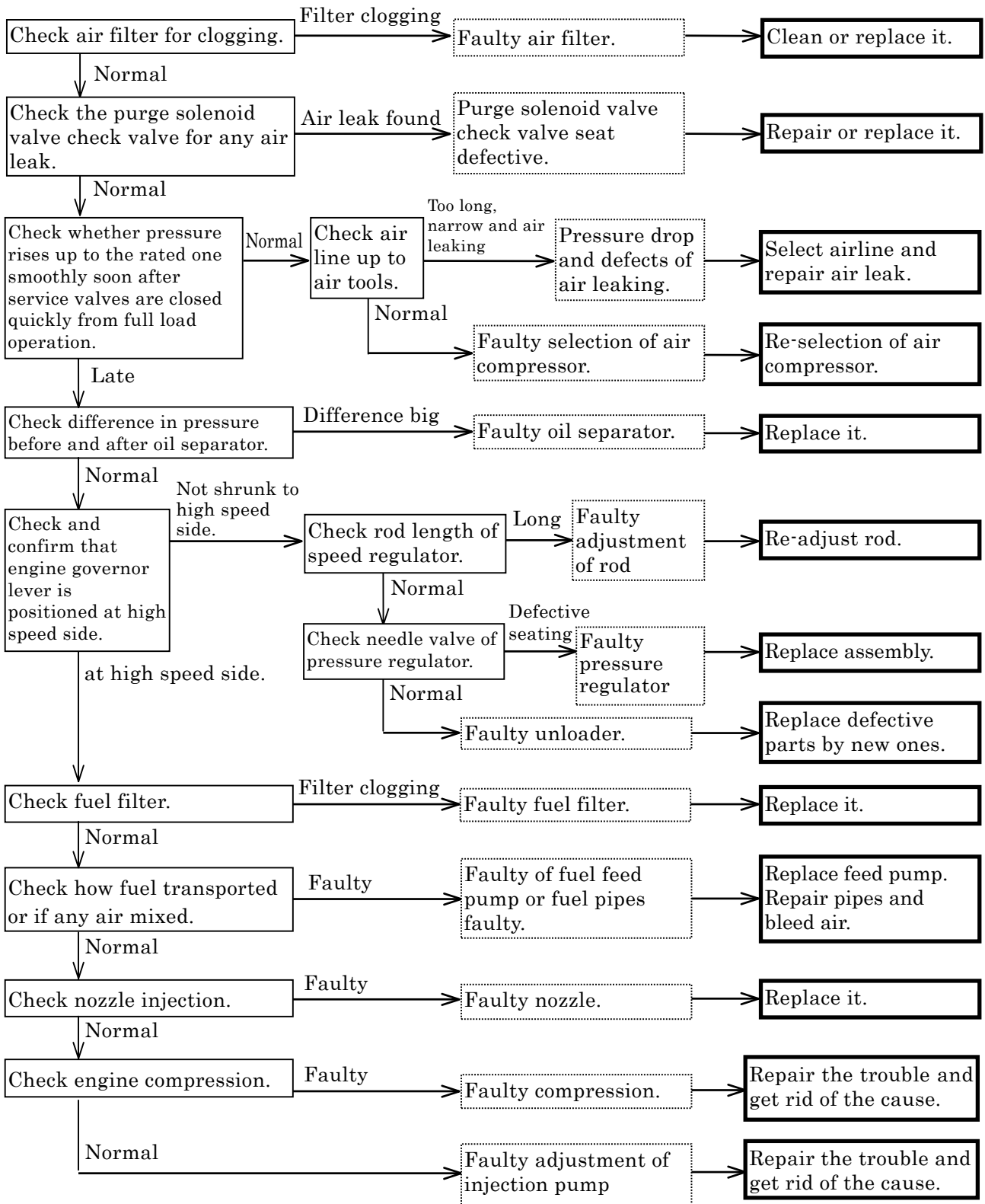

4. Troubleshooting

4.2.9 Purge control operation will not start even if auto idle switch is pressed

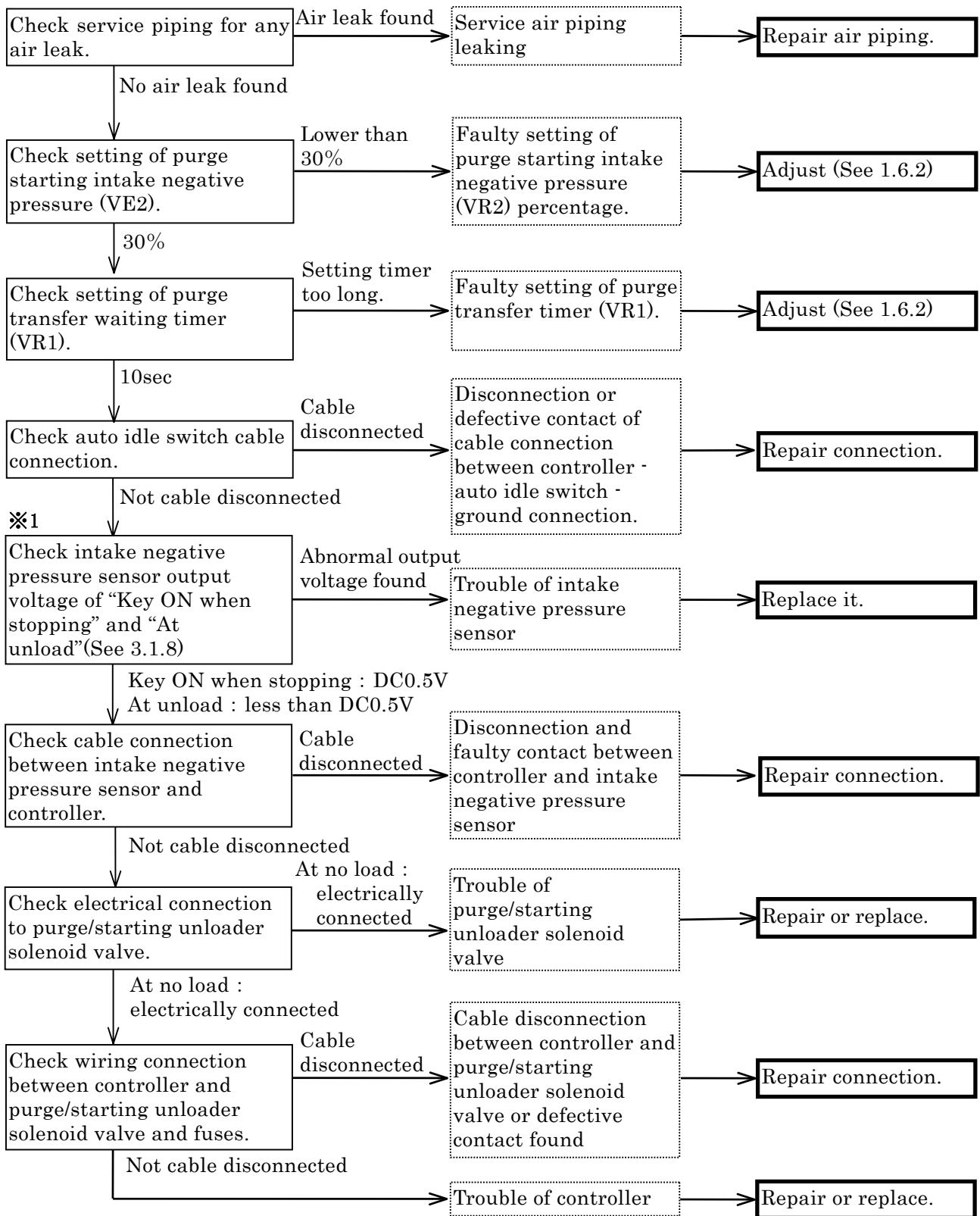

※1 : As the output voltage of intake negative pressure sensor at unload operation is very little, it is better to check the function of purge control operation after replacing the sensor with new one, if it is found difficult to diagnose the trouble.

4. Troubleshooting

4.2.10 Even when the pressure at consumer's side drops, it will not recover from purge control operation.

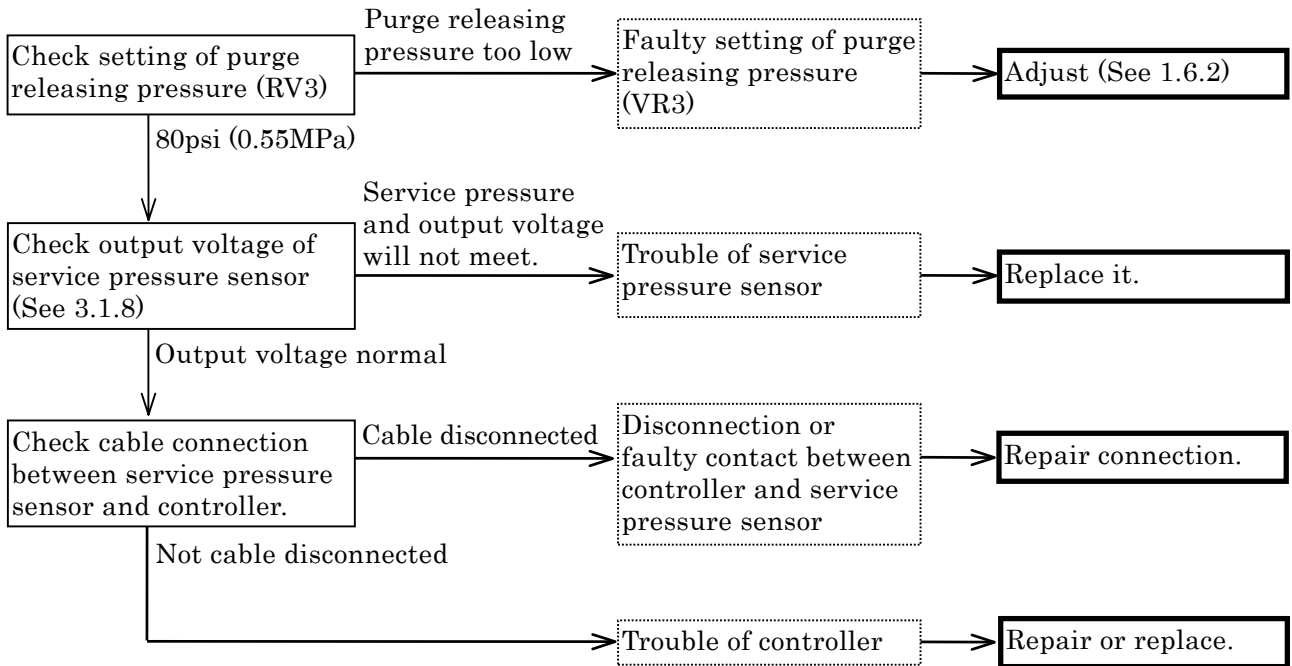

4. Troubleshooting

4.3 Operation of emergency switch

4.3.1 Discharge air temperature warning lamp glows and engine stops.

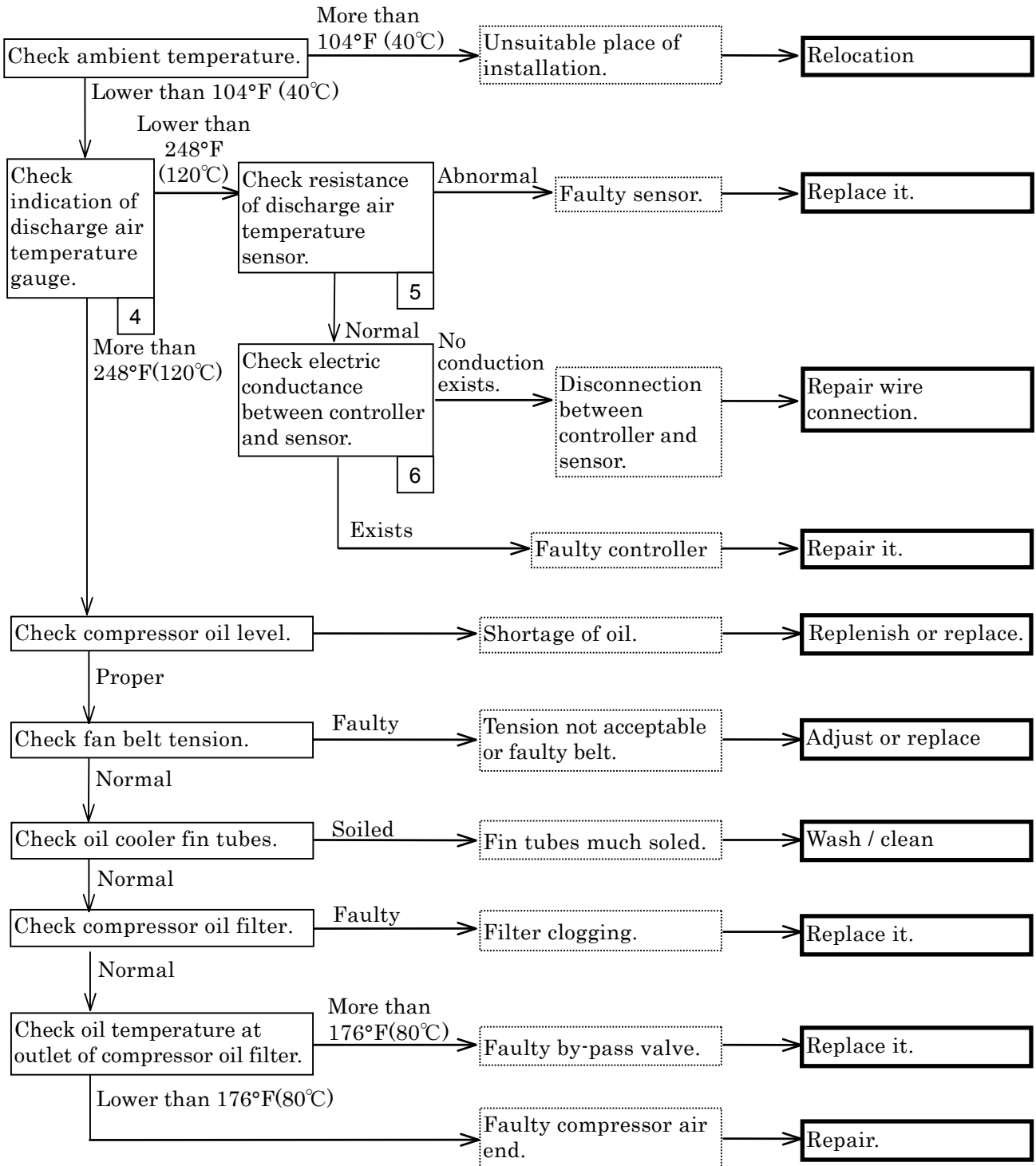

4. Troubleshooting

4.3.2 Engine oil pressure warning lamp glows and engine stops

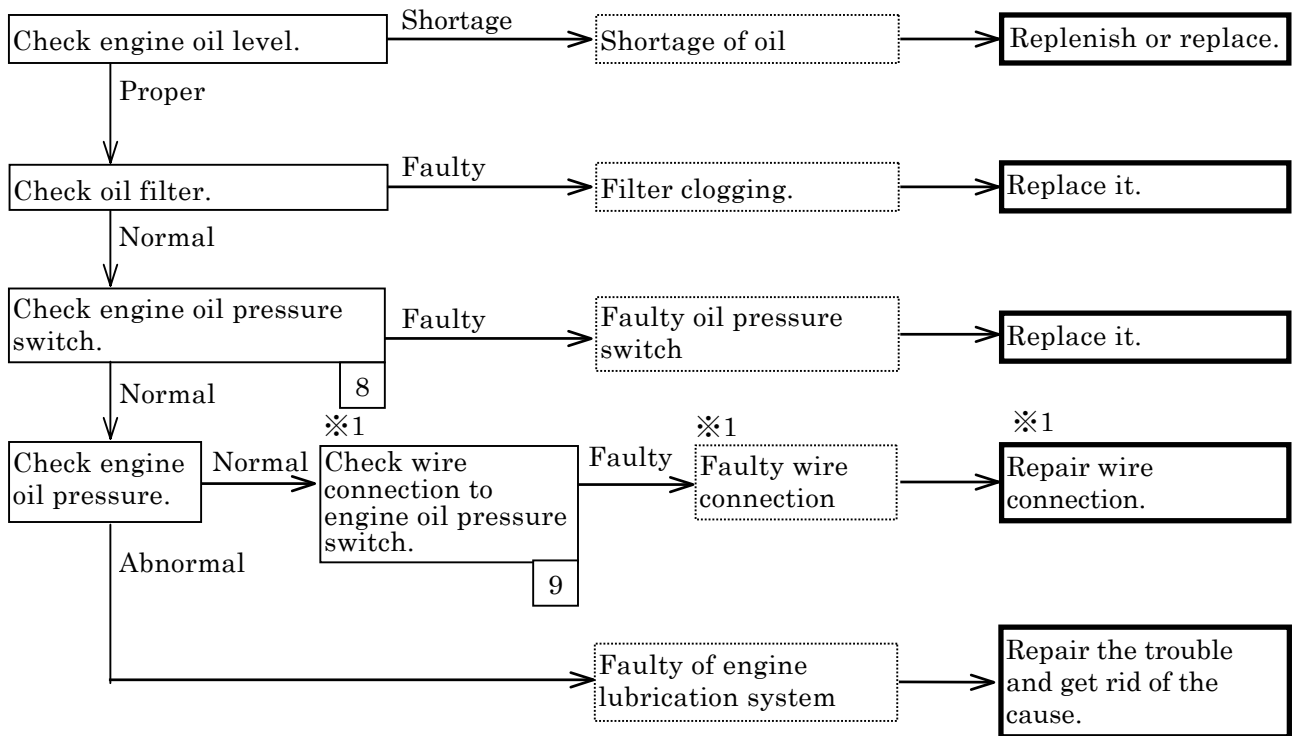

4. Troubleshooting

4.3.3 Engine coolant temperature warning lamp glows and engine stops

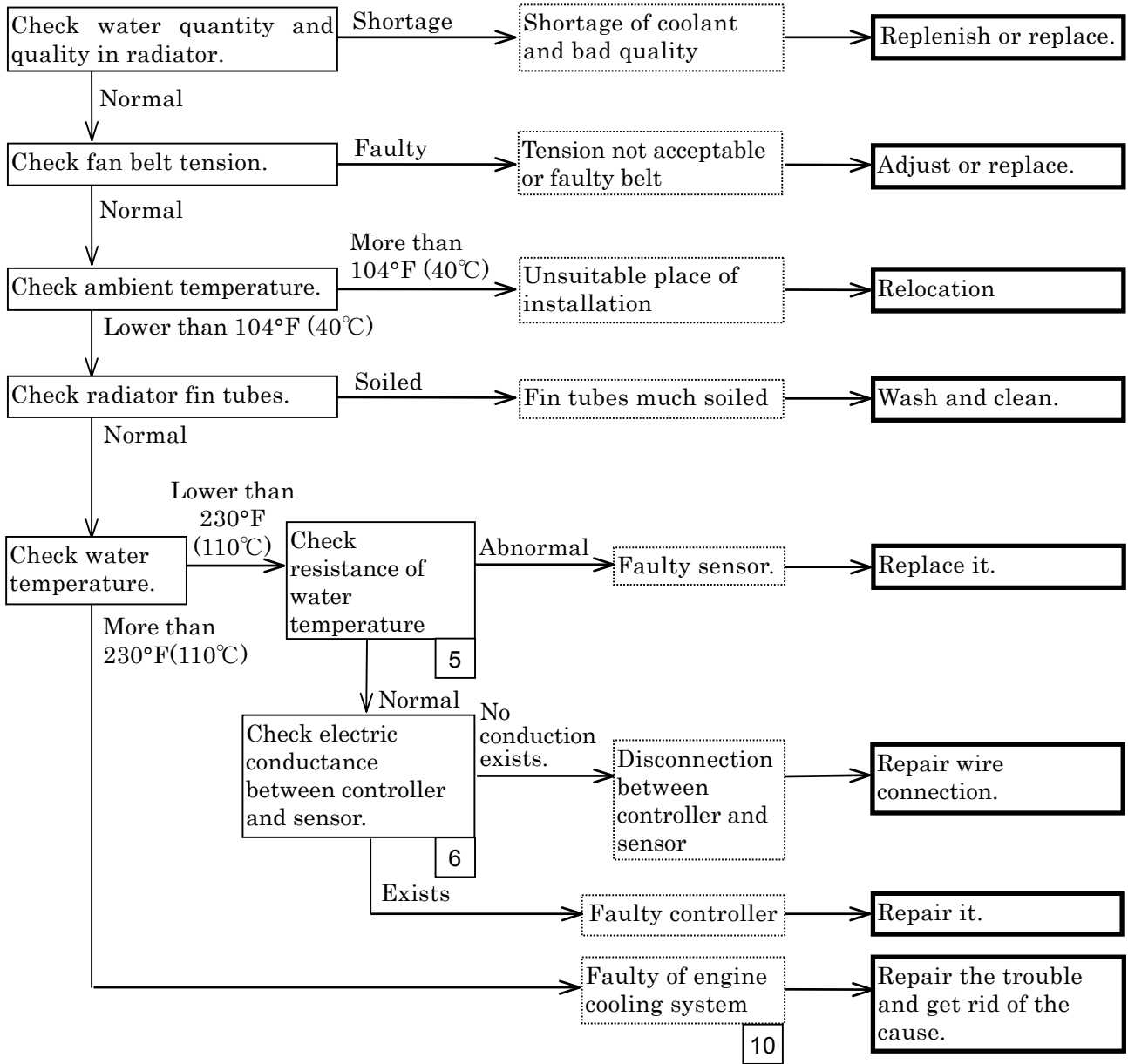

4.3.4 Residual fuel level warning lamp goes on and engine stops (PDS185S-6C1 VE PUMP Type only)

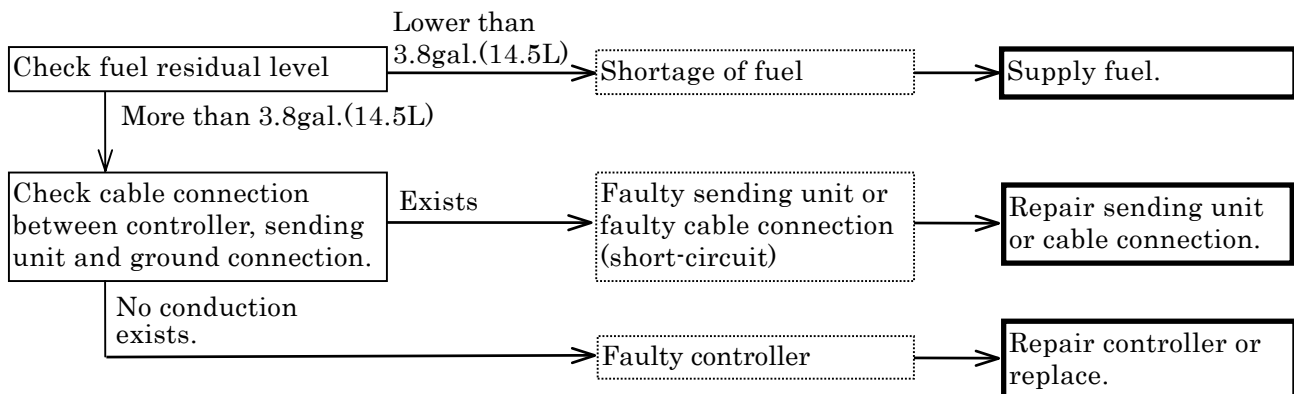

4. Troubleshooting

4.3.5 Fuel filter drain warning lamp glows and engine stops (PDS185S-6C1 VE PUMP Type only)

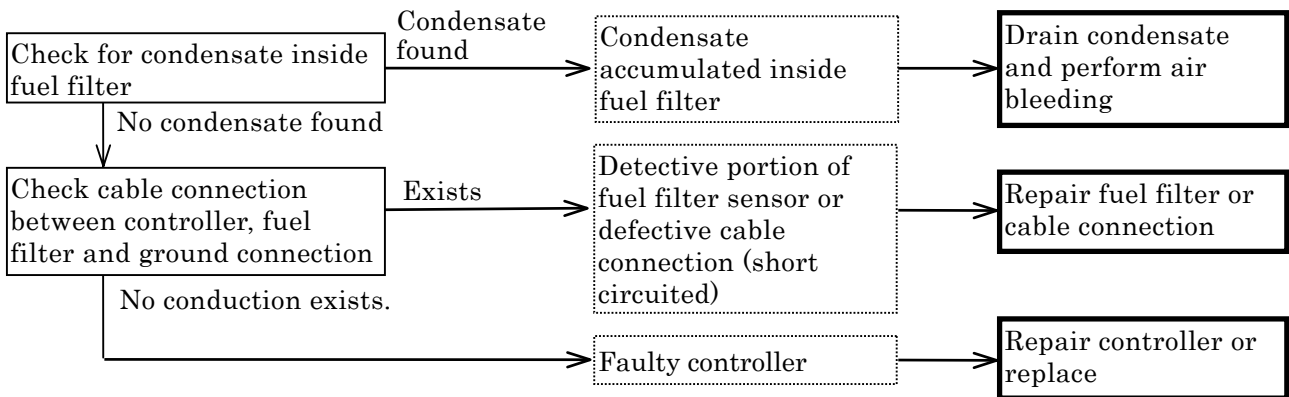

4.4 Others

4.4.1 Warning lamps will not glow, but engine stops.

(Starter switch is not set in contact, and primary circuit of battery relay is not connected properly. Blown fuse trouble is exempted.)

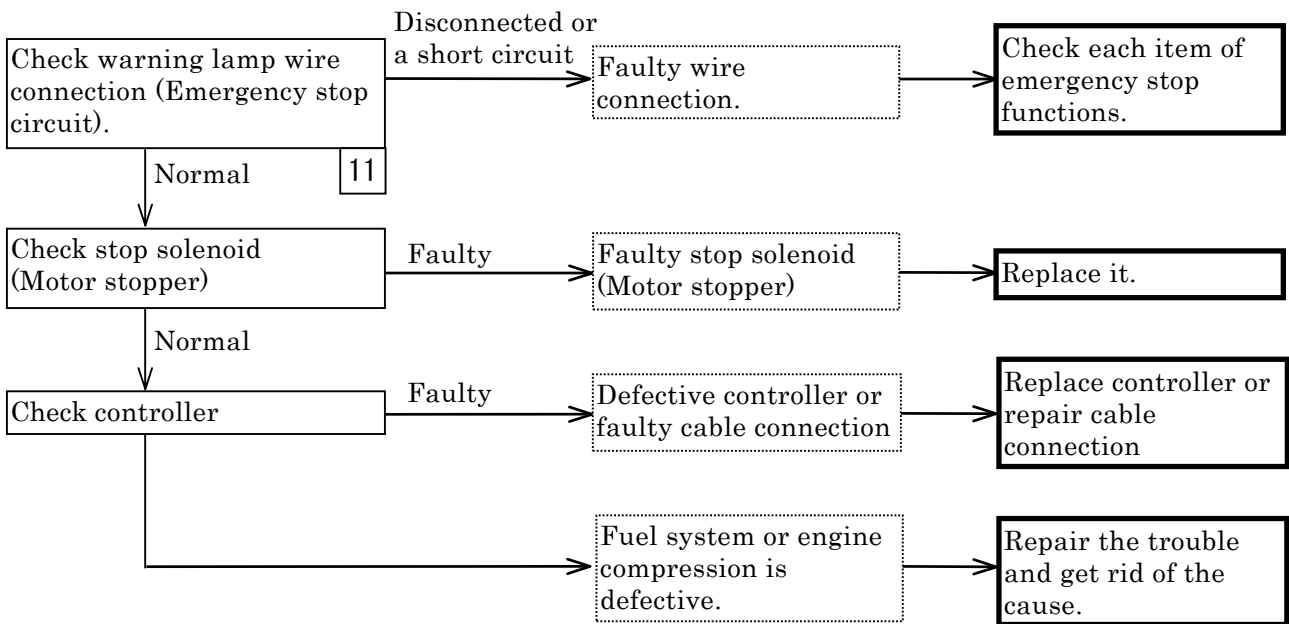

4. Troubleshooting

4.5 Explanation of trouble diagnosis

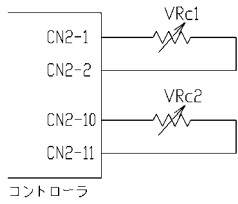
No.	Item	Cause	Remedy
1	Faulty unloader.	Unloader valve cannot be open.	Disassemble unloader valve, and check the function of valve and piston. Further check unloader orifice for any clogging.
2	Check and confirm that safety valve functions at lower pressure than set pressure for safety valve.	Check and locate pressure maladjustment or defective safety valve.	In case of malfunction of safety valve, safety valve assembly should be replaced.
3	Faulty unloader.	Faulty seat of unloader valve or faulty sliding function of valve and piston.	Disassemble unloader valve, and clean seat surface and check function of valve and piston.
4	Check discharge air temperature, using digital monitor.	Check whether actual rise of discharge air temperature stops engine or any failure of electrical circuit stops engine.	
5	Check the resistance of discharge air temperature/coolant temperature sensor.	For resistance characteristics of discharge air temperature and coolant temperature sensor, See 3.1.6.	Engine could stop even due to disconnection of thermo sensor or thermo sensors short-circuit.
6	Check conductance between controller and discharge air temperature sensor/coolant temperature sensor.	Check whether there is any disconnection or short-circuit in cable connection between controller, discharge air temperature sensor and coolant temperature sensor. Clarify whether the trouble is caused by faulty cable connection or defective controller. When discharge air temperature/coolant temperature exceeds the set temperature 248°F/230°F (120°C /110°C), interior contact between controller CN1-8 and CN1-4 terminals turns OFF to cut electrical connection to stop solenoid and making engine stop.	How to check controller only is shown as follows: Connect variable resistor (1kΩ) to controller as shown below. Gradually lowering resistance value, measure the value when it begins to show abnormality and check whether it is within the ranges shown below. 

Item	Set temperature		Resistance
	°C	°F	
Discharge air temperature VRc1	115°C	239° F	491 ± 15 Ω
	120°C	248° F	432 ± 15 Ω
Engine water temperature VRc2	107°C	225° F	608 ± 15 Ω
	110°C	230° F	560 ± 15 Ω

4. Troubleshooting

No.	Item	Cause	Remedy
7	Check engine oil pressure switch.	For actuation pressure of oil pressure switch, See 1.2 "List of set values".	
8	Check for any defective connection.	Check and make sure that no disconnection has been found for engine oil pressure switch (Switching "OFF" engine oil pressure switch enables engine emergency stop.)	
9	Faulty of engine cooling system.	When any trouble is not found in thermostat, coolant pump can be in disorder.	For the temperature at which thermostat valve opens, refer to 2.6.
10	Check warning lamp wire connection.	It sometimes happens that emergency stop circuit is active, but warning lamp will not light on because its circuit is in trouble. Try to locate its cause.	

5. References

5.1 Comparison between consumable parts and electrical appliances

Item	PDS185S-6C1 VE PUMP Type (for 55HP USA)	PDS185S-6C1 VE PUMP Type (for 49HP USA)	PDS185S-6C1R IN LINE PUMP Type (for Asian countries)
●Element			
Air filter ASS'Y (For compressor)	32100 40900	←	←
Air filter element	32143 11800	←	←
Air filter ASS'Y (For engine)	32100 40500	←	←
Air filter element	32143 11500	←	←
Oil Separator	34220 16100	←	←
For Oil Separator O-ring	03402 15140	←	←
Compressor oil filter ASS'Y	37400 13600	←	←
Oil filter cartridge	37438 05501	←	←
Engine oil filter element	41290 00900 (NISSAN:15208 43G0A)	←	←
Fuel filter cartridge	43543 01100 (NISSAN: 16403 59E0A)	←	43541 00700 (NISSAN: 16403 J5500)
Filter for fuel air bleeding electromagnetic pump	—	—	43540 05600 (NISSAN: 16400 H8501)
●Air control			
Speed regulator	36400 21400	36400 21900	36400 21400
Diaphragm	36437 01500	←	←
Pressure regulator	36400 19000	←	←
Auto relief valve	—	←	←
Vacuum relief valve	(Unloader built-in type)	←	←
Needle valve	36429 00800	←	←
O-ring	03402 25008	←	←
O-ring	03402 25021	←	←
O-ring	21221 02100	←	←
Unloader valve	22100 40300	←	←
O-ring	03402 10125	←	←
O-ring	03402 10070	←	←
O-ring	21441 04800	←	←
O-ring	21441 04900	←	←
Pressure control valve	35300 17000	←	←
O-ring	03402 15075	←	←
O-ring	03402 25032	←	←
Spring	22144 07700	←	←
Piston	35303 03300	←	←
●Instruments on panel			
Starter switch	44322 07200	←	←
Pressure gauge	36141 18600	←	36141 15503
Fuel level gauge	36158 00500	←	←
Hour meter	36149 02800	←	←
●Oil line			
By-pass valve ASS'Y	37200 11500	←	←
Pellet	37231 02100	←	←
O-ring	03402 25045	←	←

5. References

Item	PDS185S-6C1 VE PUMP Type (for 55HP USA)	PDS185S-6C1 VE PUMP Type (for 49HP USA)	PDS185S-6C1R IN LINE PUMP Type (for Asian countries)
●Electrical appliances			
Purge/starting unloader solenoid	46811 24100	←	←
controller	46879 41400	←	46879 45700
Glow controller (QGS II)	44327 04100 (NISSAN: 11067 90063)	←	←
Glow relay (GR)	44346 07200	←	←
Starter relay (SR)	44346 07200	←	←
Motor stopper	—	—	44358 01200 (NISSAN: 19801 90011)
Motor stopper relay (MSR)	—	—	44346 07300 (NISSAN: 25230 C9900)
Fuse 10A	46934 03200	←	←
Fuse 20A	—	—	46934 03300
Intake negative pressure sensor	44328 20600	←	←
Service pressure sensor	44328 20600	←	←
Discharge air temp. sensor	44364 06500	←	←
Coolant temp. sensor	44364 06500	←	←
Engine oil pressure switch	44328 19100	←	←
Purge Control switch	46167 02900	←	←
Sending unit	36159 04100	←	←

5.2 Engine Wiring Diagram

PDS185S-6C1 VE PUMP Type

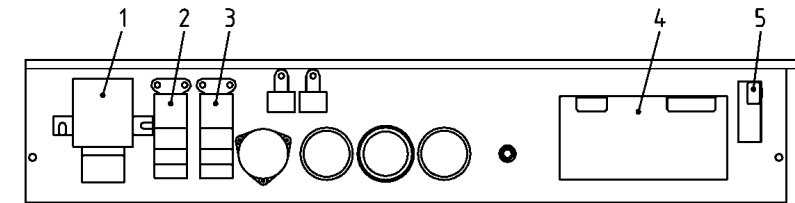
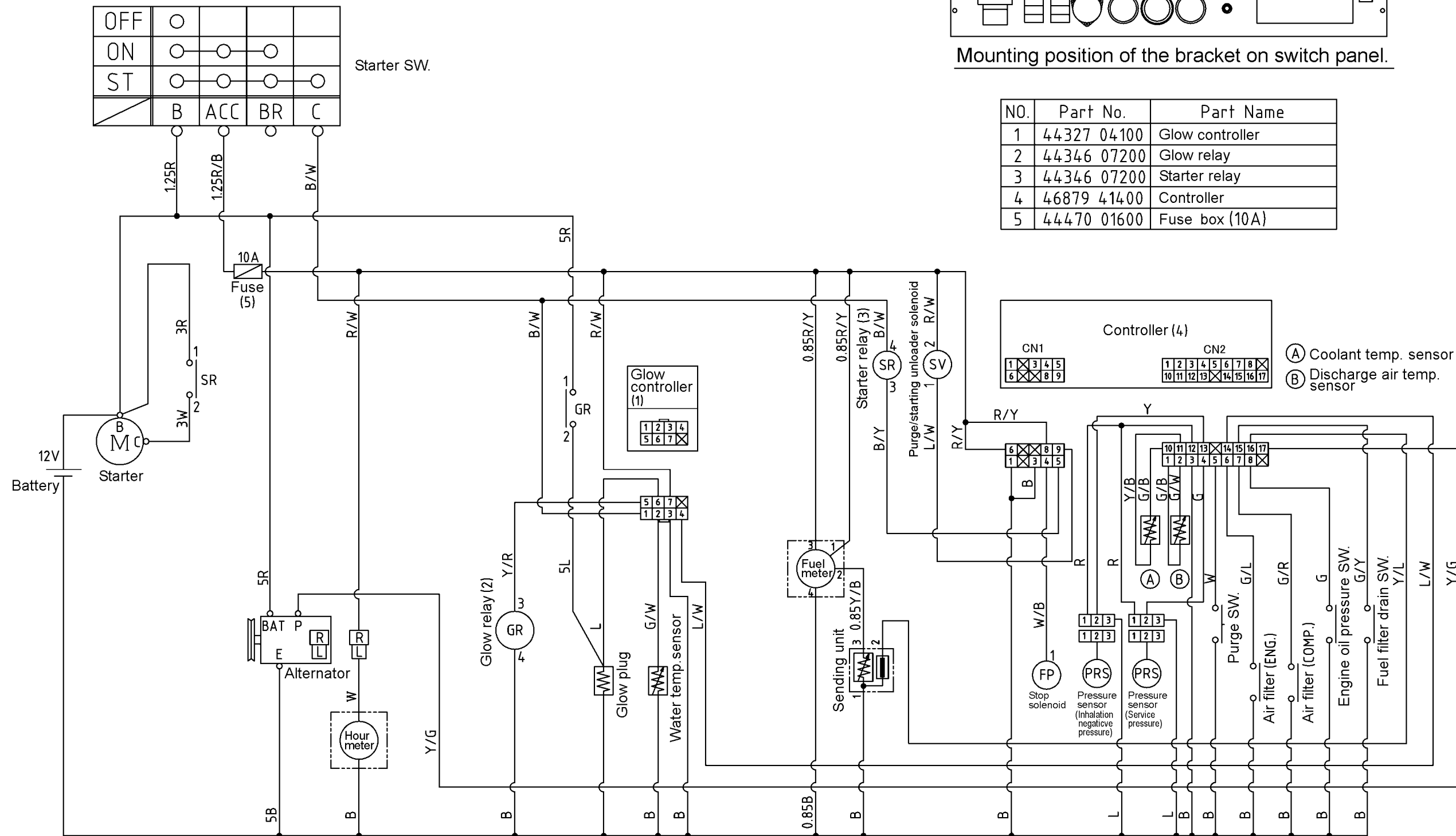

Mounting position of the bracket on switch panel.

NO.	Part No.	Part Name
1	44327 04100	Glow controller
2	44346 07200	Glow relay
3	44346 07200	Starter relay
4	46879 41400	Controller
5	44470 01600	Fuse box (10A)

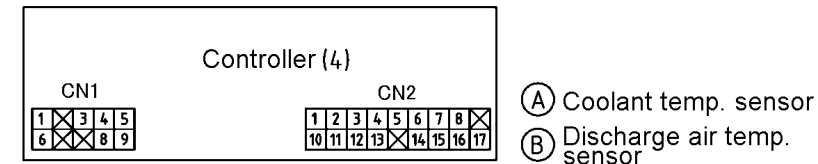

The wire size without directions is 0.5mm².

PDS185S-6C1R IN LINE PUMP Type

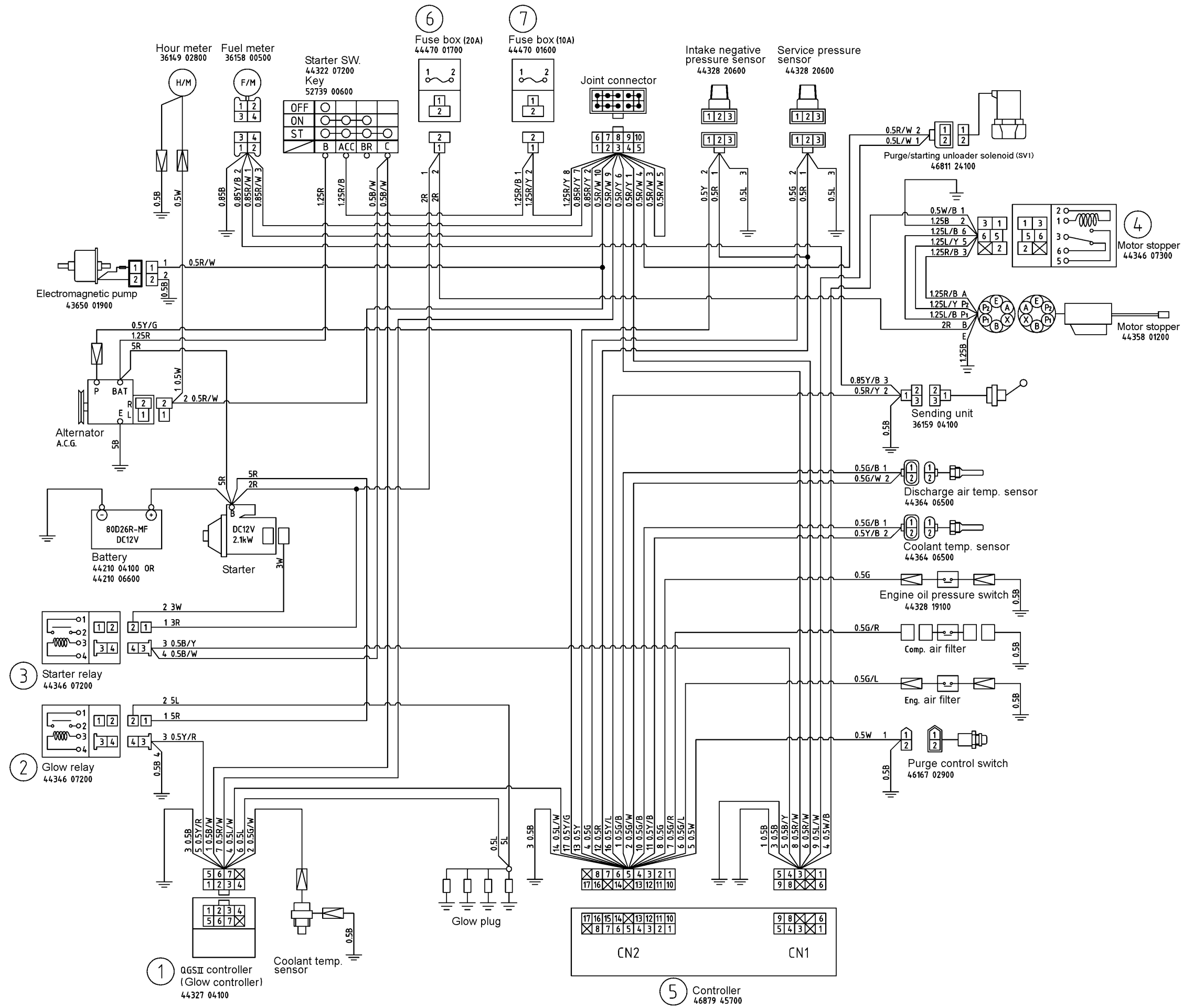

This text book contains the most recent information available at the time of printing, and the contents of the list are based on information in effect at that time and are subject to change without notice.

HOKUETSU INDUSTRIES CO., LTD.

8TH FLOOR SHINJUKU SAN-EI BLDG,
22-2 NISHI-SHINJUKU 1-CHOME, SHINJUKU-KU
TOKYO 160-0023 JAPAN
TEL:81-3-3348-7281
FAX:81-3-3348-7289
URL:<http://www.airman.co.jp>

Copyright(C)2010 HOKUETSU INDUSTRIES CO., LTD. All Rights Reserved

NPC-0052
PRINTED IN JAPAN 2010. 1



AIRMAN
HOKUETSU INDUSTRIES CO., LTD.