

Elektrischer Anschluß
electrical connection

Austritt Druckluft
Outlet compressed air
BSPP-F G 1/2" ISO 228-1

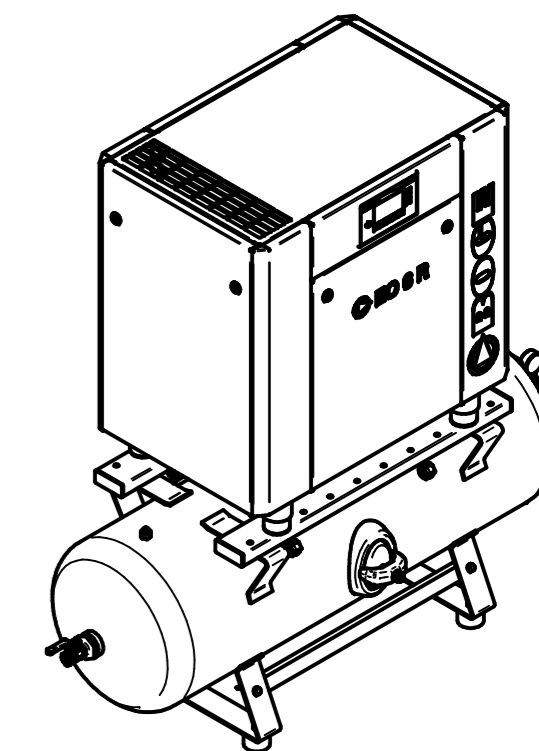
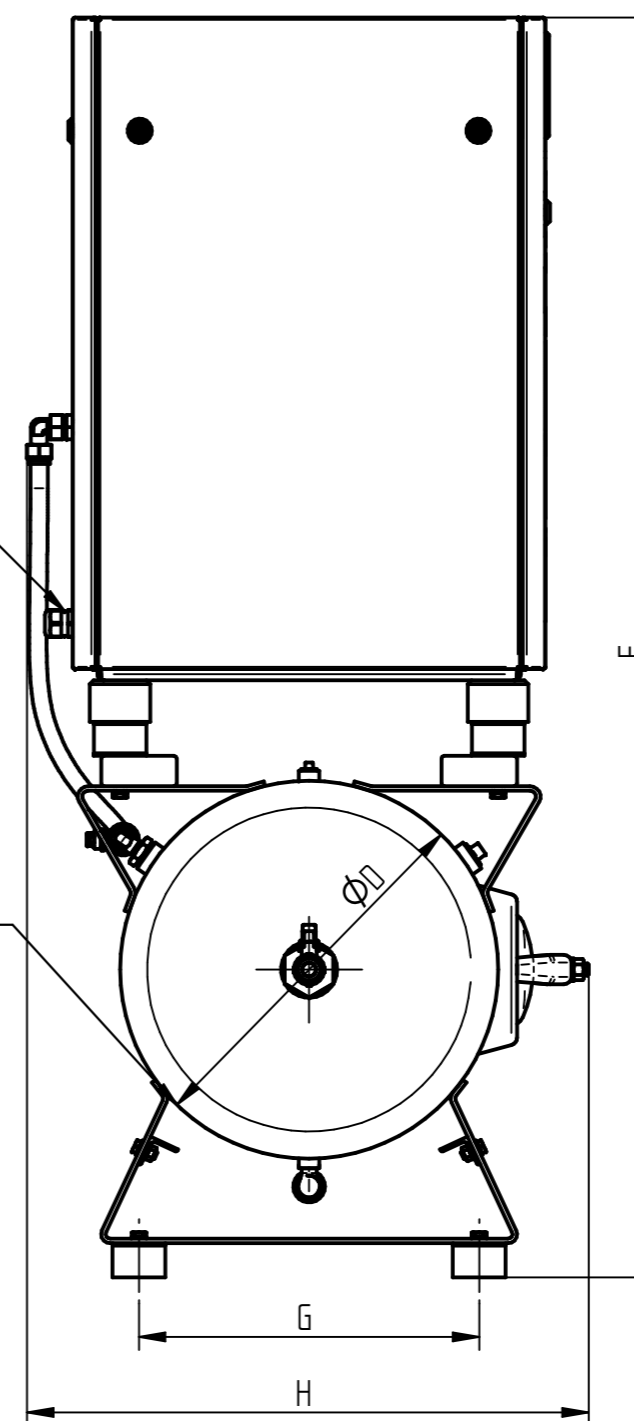

1:20

1. Gewicht (+/- 10 kg / +/- 22 lbs)
Weight
2. Statische Belastungen pro Auflager
Static loads per abutment
3. Kühlluftbedarf
Cooling air requirement
4. Erforderlicher Kühlluftstrom der Ventilation
Required cooling air flow for ventilation
5. Erforderlicher Querschnitt Zuluft
Required cross section supply air

Bei Einbau von Widerständen in Zuluft und/oder Abluft sind die Querschnitte, Kühlluftbedarfe, Volumenströme des Ventilators entsprechend zu erhöhen.

When installing resistors in supply and/or exhaust the cross sections, cooling air requirements, flow rates of the fan should be increased accordingly.

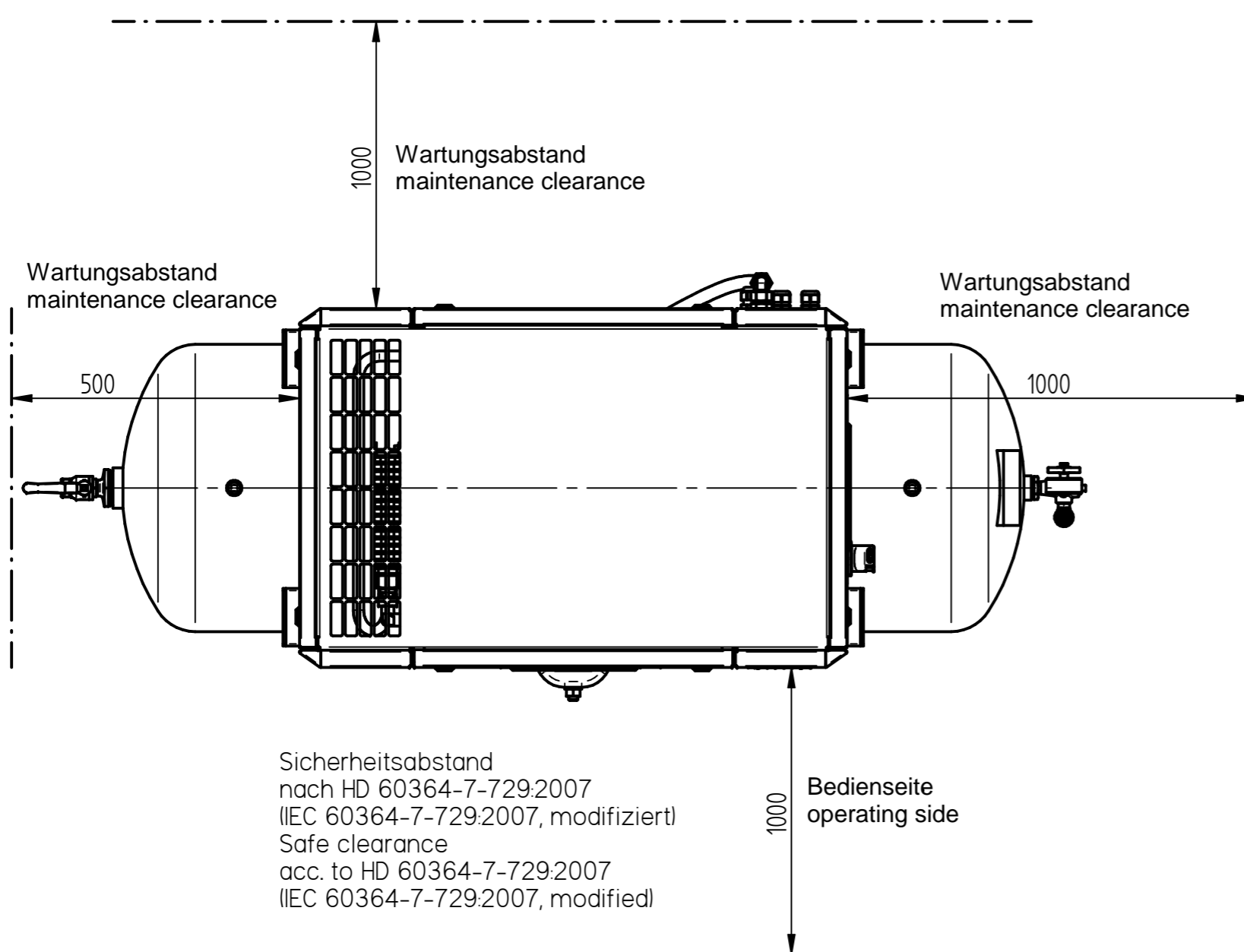

Technische Daten / Technical data					
	1."	2.	3.	4.	5.
	-	-	-	nach / acc. VDMA 4363:1978	nach / acc. VDMA 4363:1978
Maschine / type	kg	N/cm ²	m ³ /h	m ³ /h	m ²
EO 4 R 270L	333	22	360	1200	0,18
EO 4 R 350L	355	23	360	1200	0,18
EO 4 R 500L	385	25	360	1200	0,18
EO 6 R 270L	368	24	780 (8bar) / 660 (10bar)	1500	0,25
EO 6 R 350L	390	25	780 (8bar) / 660 (10bar)	1500	0,25
EO 6 R 500L	420	27	780 (8bar) / 660 (10bar)	1500	0,25

Abmaße / dimensions								
Maschine / Type	A	B	C	D	E	F	G	H
EO 4 R 270L	1785	800	490	500	410	1670	450	745
EO 4 R 350L	1825	800	525	550	430	1725	550	770
EO 4 R 500L	1975	800	600	600	475	1785	550	795
EO 6 R 270L	1785	800	490	500	410	1670	450	745
EO 6 R 350L	1825	800	525	550	430	1725	550	770
EO 6 R 500L	1975	800	600	600	475	1785	550	795

Technische Änderungen vorbehalten. All rights reserved for technical changes.		Maßstab / Scale 1:10	
Zugsart / Drawing type Masszeichnung		Dokumentenstatus / Document status Freigegeben	
Benennung / Designation Druckluft-Anlage / Compressed air plant EO 4-6 R Behälter / Receiver			
Datum / Date Erstellt / Created 24.05.2016 Freigabe / Released 29.11.2017 Name / Name BUDT ARNDT		Zeichnungsnummer oder DOK-ID / Drawing number or DOK-ID M2200.1107	
Blatt / Sheet 1 of sheets		Erst. d. / Replacement for Erst. d. / Replacement by	
DOK-ID 2205410/SDN/001/01 Weitergabe sowie Vervielfältigung dieser Dokumente, Verwertung und Mitteilung seines Inhalts sind verboten, soweit nicht ausdrücklich gestattet. Zweitanhandlungen verpflichten zu Schadenersatz. Alle Rechte für den Fall der Patent-, Gebrauchsmuster- oder Geschmacksmusterregistrierung vorbehalten. The reproduction, distribution and utilization of this documents as well as the communication of its contents to others without expressed authorization is prohibited. Offenders will be held liable for the payment of damages. All rights reserved in the event of the grant of patent, utility model or ornamental design registration.			